

Sample Mathematics Problems

08-09

FOR GRADE 9

DIRECTIONS: This section provides sample mathematics problems for the Grade 9 test forms. These problems are based on material included in the New York City curriculum for Grade 8. (The Grade 8 problems on sample forms A and B cover mathematics material through Grade 7.) Directions on how to answer math questions are located on pages 46 and 82. There is no sample answer sheet for this section; mark your answers directly on this page or on a separate piece of paper.

1. In 1960, the number of tons of solid waste produced by a city was 75 million. In 1990, the number of tons was 180 million. By what percentage did the solid waste tonnage increase from 1960 to 1990?

A. 70%
 B. 75%
 C. 105%
 D. 140%
 E. 240%

$$\frac{\text{new-old}}{\text{old}} = \frac{180-75}{75} = \frac{105}{75} = \frac{7}{5} = \frac{140}{100}$$

2.

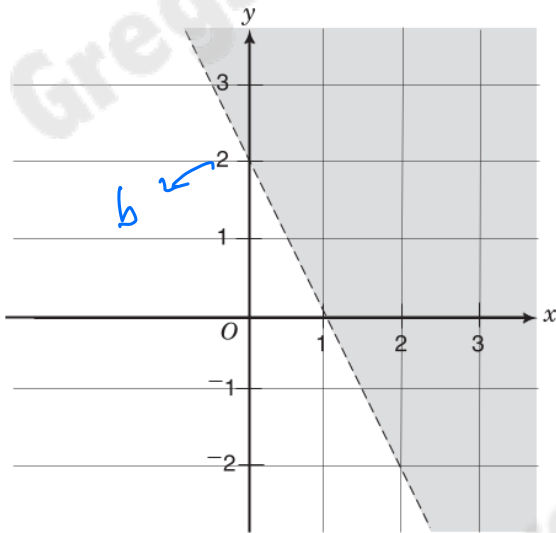

Which inequality has the shaded region in the diagram above as its graph?

- F. $y \leq -2x + 2$
 G. $y < -2x + 2$
 H. $y \geq -2x + 2$
 J. $y > -2x + 2$
 K. $y = -2x + 2$
- Slope = $\frac{\Delta y}{\Delta x} = \frac{\text{rise}}{\text{run}} = \frac{y_2 - y_1}{x_2 - x_1}$
 Using (0, 2) and (1, 0)
- $$\frac{2-0}{0-1} = \frac{2}{-1} = -2$$
- $$y = mx + b$$

$$= -2x + 2$$

Shaded is above so greater than
 line is dashed so not equal
 $\therefore y > -2x + 2$

3. Jessenia usually earns \$25 each week. Last week, she received an extra \$20 in bonus. What percent of her usual weekly income was her total income last week?

A. 10%
 B. 45%
 C. 80%
 D. 180%
 E. 225%

$$25 + 20 = 45$$

$$45 = x\% \cdot 25$$

$$45 = \frac{x}{100} \cdot 25$$

$$x = 180$$

4. Let $M' = (12, 12)$ and $N' = (24, 12)$. If $\overline{M'N'}$ is the dilated image of \overline{MN} , where $M = (5, 5)$, what are the coordinates of point N?

F. (17, 7)
 G. (10, 5)
 H. (7.5, 5)
 J. (0.2, 0.1)
 K. (0.1, 0.2)

Scale: $\frac{12}{5}$
 $\frac{12}{5}x = 24 \Rightarrow x = 10$
 $\frac{12}{5}y = 12 \Rightarrow y = 5$

5. n is an integer smaller than -2 . What is the range of possible values of $\frac{1}{n^2}$?

A. $\frac{1}{n^2} < -4$
 B. $\frac{1}{n^2} > 4$
 C. $0 < \frac{1}{n^2} < \frac{1}{4}$
 D. $-\frac{1}{4} < \frac{1}{n^2} < 0$
 E. $-\frac{1}{2} < \frac{1}{n^2} < \frac{1}{2}$

$n < -2$ (positive)
 a) $n^2 > 0 \Rightarrow \frac{1}{n^2} > 0$
 b) $n^2 > 4 \Rightarrow \frac{1}{4} > \frac{1}{n^2}$

6.

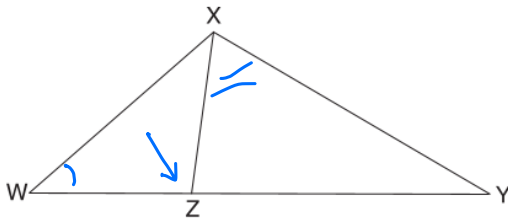

\overline{WZY} is a straight line segment and $\triangle XWZ$ is congruent to $\triangle XYZ$. What can one conclude about $\angle XZW$? (The figure is not drawn to scale.)

- F. $\angle XZW$ is a right angle.
- G. $\angle XZW$ is larger than $\angle XZY$.
- H. $\angle XZW$ is smaller than $\angle XZY$.
- J. $\angle XZW$ has the same measure as $\angle XYZ$.
- K. $\angle XZW$ has the same measure as $\angle YXZ$.

7. Simplify $\frac{e^2 \cdot e^3}{e^6} = \frac{e^5}{e^6} = e^{-1}$

- A. 1
- B. e^0
- C. e^{-1}
- D. $e^{\frac{5}{6}}$
- E. e

8.

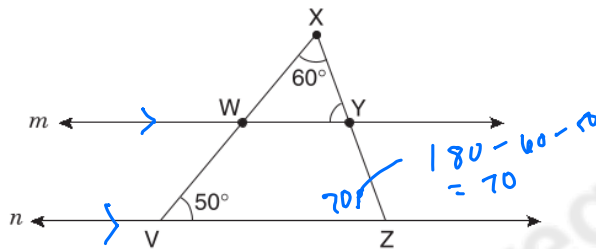

line $m \parallel$ line n

\overline{WX} is a straight line segment, and W and Y are points on line m . What is the measure of $\angle XYW$?

- F. 40°
- G. 50°
- H. 60°
- J. 70°
- K. 80°

9.

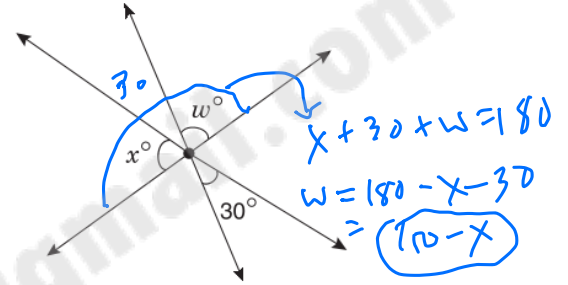

In the figure above, three lines intersect at a point. What is the value of w in terms of x ?

- A. $150 - x$
- B. $165 - x$
- C. $180 - x$
- D. $150 - 2x$
- E. $30 + x$

10.

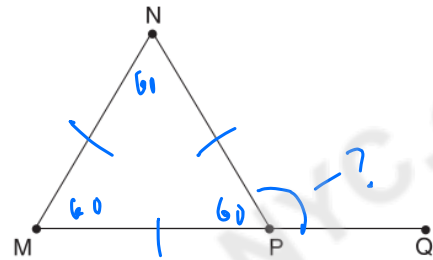

In this figure, $MN = NP = PM$ and \overline{MPQ} is a straight line segment. What is the measure of $\angle NPQ$?

- F. 60°
- G. 90°
- H. 100°
- J. 120°
- K. 150°

Equilateral Triangle
 \therefore all angles = 60
 a) $180 - 60 = 120$
 or b) external angle NPQ is sum of interior opposite angles NMP & NMP

11.

Let $P = (2, 3)$. First, translate P one unit to the right and call the image R. Next, reflect R over the y -axis and call the image S. Finally, rotate S 90° clockwise about the origin and call the image T. What are the coordinates of T?

- A. $(-3, -3)$
- B. $(-2, -3)$
- C. $(-2, 3)$
- D. $(3, -3)$
- E. $(3, 3)$

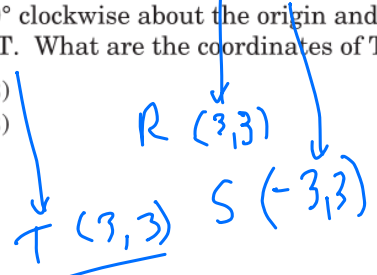

12. The radius of circle C_1 is R , and that of circle C_2 is r . The area of C_1 is twice that of C_2 . What is R in terms of r ?

F. $\frac{1}{2}r$ $A_{C_1} = \pi R^2$
 G. $\frac{1}{\sqrt{2}}r$ $A_{C_2} = \pi r^2$
 H. $\sqrt{2}r$ $A_{C_1} = 2A_{C_2}$
 J. $2r$
 K. $4r$

$\frac{\pi R^2}{\pi} = \frac{2(\pi r^2)}{\pi}$
 $R^2 = 2r^2$
 $R = \sqrt{2r^2} = \sqrt{2}r$

13.

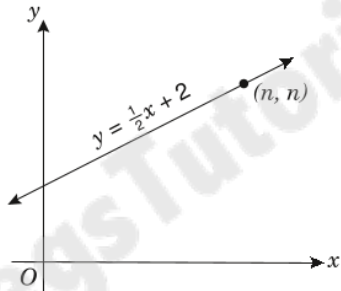

What is the value of n in the figure above?

- A. 1
 B. 2
 C. $2\frac{1}{2}$
 D. 3
 E. 4

$4 = \frac{1}{2}(4) + 2$
 $4 = 2 + 2 = 4 \checkmark$

14.

$x^2 = P$ 36
 $x^2 \cdot x = Q$ -216
 $x^2 \div x = R$ -6
 $x^2 + x = S$ 30
 $x^2 - x = T$ 42

If $x = -6$ in the equations above, which letter has the greatest value?

- F. P
 G. Q
 H. R
 J. S
 K. T

15.

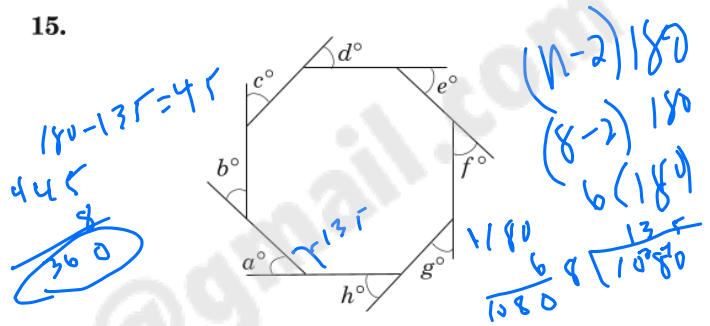

The figure above is a regular octagon. What is the sum of the measures of the exterior angles ($a + b + c + d + e + f + g + h$)?

- A. 30
 B. 45
 C. 135
 D. 360
 E. 1,080
- Sum exterior angles of a polygon is 360

16.

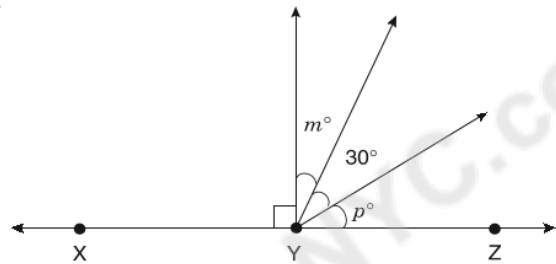

In the figure above, Y is a point on line \overleftrightarrow{XZ} . What is the value of $m + p$?

- F. 45
 G. 60
 H. 75
 J. 90
 K. 120

$m + 30 + p = 90$
 -30
 $m + p = 60$

17.

A jar contains exactly 6 balls: 5 red and 1 blue. If 5 balls are drawn from the jar at random and without replacement, what is the probability that they are all red?

- A. $\frac{1}{6}$
 B. $\frac{1}{5}$
 C. $\frac{5}{11}$
 D. $\frac{2}{3}$
 E. $\frac{5}{6}$

$\frac{5r}{16}$
 $\frac{5}{6} \times \frac{4}{5} \times \frac{3}{4} \times \frac{2}{3} \times \frac{1}{2} = \frac{1}{6}$

Sample Mathematics Problems

09-10

FOR GRADE 9

DUP

DIRECTIONS: This section provides sample mathematics problems for the Grade 9 test forms. These problems are based on material included in the New York City curriculum for Grade 8. (The Grade 8 problems on sample forms A and B cover mathematics material through Grade 7.) General directions for how to answer math questions are located on pages 48 and 84. There is no sample answer sheet for this section; mark your answers directly on this page or on a separate piece of paper.

1. In 1960, the number of tons of solid waste produced by a city was 75 million. In 1990, the number of tons was 180 million. By what percentage did the solid waste tonnage increase from 1960 to 1990? 09dup1
- A. 70%
 B. 75%
 C. 105%
 D. 140%
 E. 240%

2. 09dup2

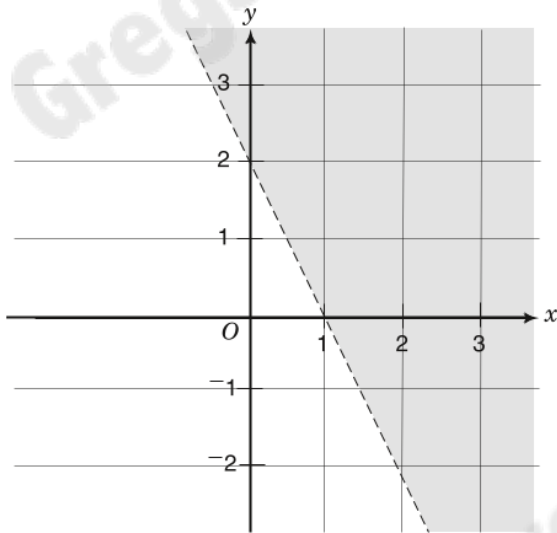

Which inequality has the shaded region in the diagram above as its graph?

- F. $y \leq -2x + 2$
 G. $y < -2x + 2$
 H. $y \geq -2x + 2$
 J. $y > -2x + 2$
 K. $y = -2x + 2$

3. Jessenia usually earns \$25 each week. Last week, she received an extra \$20 in bonus. What percent of her usual weekly income was her total income last week? 09dup3
- A. 10%
 B. 45%
 C. 80%
 D. 180%
 E. 225%

4. Let $M' = (12, 12)$ and $N' = (24, 12)$. If $\overline{M'N'}$ is the dilated image of \overline{MN} , where $M = (5, 5)$, what are the coordinates of point N? 09dup4
- F. (17, 7)
 G. (10, 5)
 H. (7.5, 5)
 J. (0.2, 0.1)
 K. (0.1, 0.2)

5. n is an integer smaller than -2 . What is the range of possible values of $\frac{1}{n^2}$? 09dup5
- A. $\frac{1}{n^2} < -4$
 B. $\frac{1}{n^2} > 4$
 C. $0 < \frac{1}{n^2} < \frac{1}{4}$
 D. $-\frac{1}{4} < \frac{1}{n^2} < 0$
 E. $-\frac{1}{2} < \frac{1}{n^2} < \frac{1}{2}$

6.

09dup6

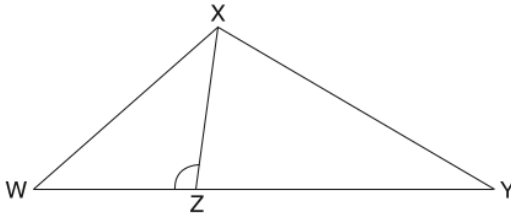

\overline{WZY} is a straight line segment and $\triangle XWZ$ is congruent to $\triangle YXZ$. What can one conclude about $\angle XZW$? (The figure is not drawn to scale.)

- F. $\angle XZW$ is a right angle.
- G. $\angle XZW$ is larger than $\angle XZY$.
- H. $\angle XZW$ is smaller than $\angle XZY$.
- J. $\angle XZW$ has the same measure as $\angle XZY$.
- K. $\angle XZW$ has the same measure as $\angle YXZ$.

7.

Simplify $\frac{e^2 \cdot e^3}{e^6}$

09dup7

- A. 1
- B. e^0
- C. e^{-1}
- D. $e^{\frac{5}{6}}$
- E. e

8.

09dup8

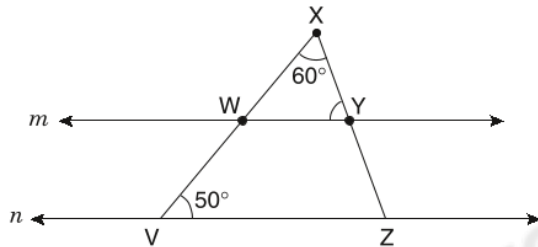

line $m \parallel$ line n

\overline{WX} is a straight line segment, and W and Y are points on line m . What is the measure of $\angle XYW$?

- F. 40°
- G. 50°
- H. 60°
- J. 70°
- K. 80°

9.

09dup9

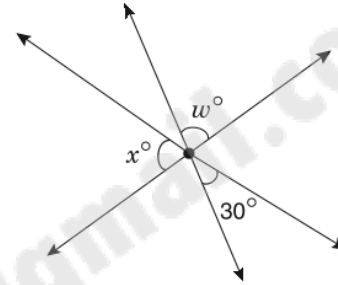

In the figure above, three lines intersect at a point. What is the value of w in terms of x ?

- A. $150 - x$
- B. $165 - x$
- C. $180 - x$
- D. $150 - 2x$
- E. $30 + x$

10.

09dup10

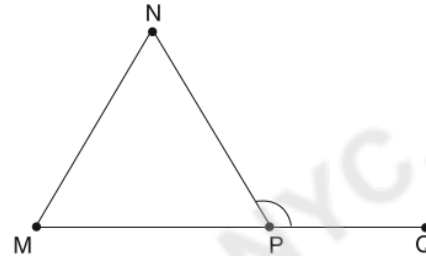

In this figure, $MN = NP = PM$ and \overline{MPQ} is a straight line segment. What is the measure of $\angle NPQ$?

- F. 60°
- G. 90°
- H. 100°
- J. 120°
- K. 150°

11.

09dup11

Let $P = (2, 3)$. First, translate P one unit to the right and call the image R . Next, reflect R over the y -axis and call the image S . Finally, rotate S 90° clockwise about the origin and call the image T . What are the coordinates of T ?

- A. $(-3, -3)$
- B. $(-2, -3)$
- C. $(-2, 3)$
- D. $(3, -3)$
- E. $(3, 3)$

09dup12

12. The radius of circle C_1 is R , and that of circle C_2 is r . The area of C_1 is twice that of C_2 . What is R in terms of r ?

- F. $\frac{1}{2}r$
 G. $\frac{1}{\sqrt{2}}r$
 H. $\sqrt{2}r$
 J. $2r$
 K. $4r$

13.

09dup13

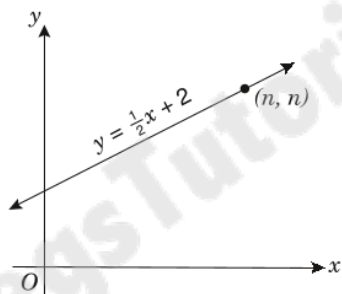

What is the value of n in the figure above?

- A. 1
 B. 2
 C. $2\frac{1}{2}$
 D. 3
 E. 4

09dup14

14.

$$\begin{aligned}x^2 &= P \\x^2 \cdot x &= Q \\x^2 \div x &= R \\x^2 + x &= S \\x^2 - x &= T\end{aligned}$$

If $x = -6$ in the equations above, which letter has the greatest value?

- F. P
 G. Q
 H. R
 J. S
 K. T

09dup15

15.

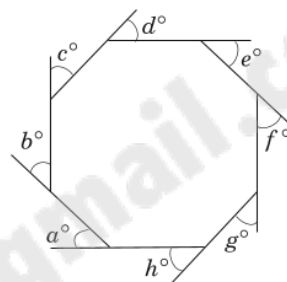

The figure above is a regular octagon. What is the sum of the measures of the exterior angles ($a + b + c + d + e + f + g + h$)?

- A. 30
 B. 45
 C. 135
 D. 360
 E. 1,080

09dup16

16.

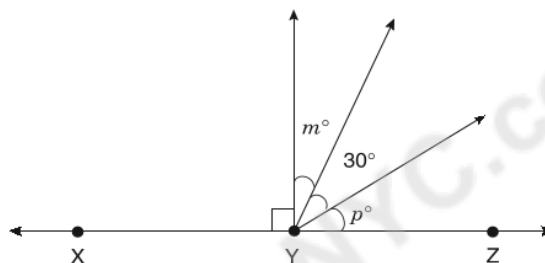

In the figure above, Y is a point on line \overleftrightarrow{XZ} . What is the value of $m + p$?

- F. 45
 G. 60
 H. 75
 J. 90
 K. 120

09dup17

17. A jar contains exactly 6 balls: 5 red and 1 blue. If 5 balls are drawn from the jar at random and without replacement, what is the probability that they are all red?

- A. $\frac{1}{6}$
 B. $\frac{1}{5}$
 C. $\frac{5}{11}$
 D. $\frac{2}{3}$
 E. $\frac{5}{6}$

FOR GRADE 9 MATHEMATICS

DUP

DIRECTIONS: This section provides sample mathematics problems for the Grade 9 test forms. These problems are based on material included in the New York City curriculum for Grade 8. (The Grade 8 problems on sample forms A and B cover mathematics material through Grade 7.) General directions for how to answer math questions are located on pages 48 and 84. There is no sample answer sheet for this section; mark your answers directly on this page or on a separate piece of paper.

- 09dup1
1. In 1960, the number of tons of solid waste produced by a city was 75 million. In 1990, the number of tons was 180 million. By what percentage did the solid waste tonnage increase from 1960 to 1990?
- A. 70%
 - B. 75%
 - C. 105%
 - D. 140%
 - E. 240%

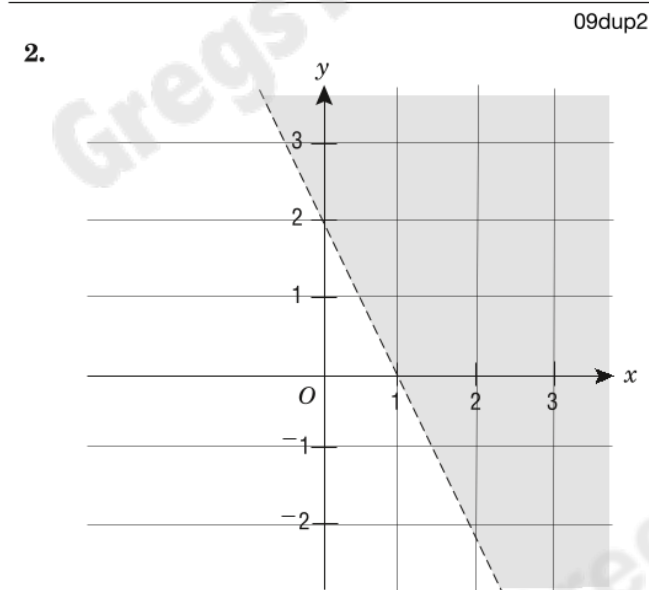

Which inequality has the shaded region in the diagram above as its graph?

- F. $y \leq -2x + 2$
- G. $y < -2x + 2$
- H. $y \geq -2x + 2$
- J. $y > -2x + 2$
- K. $y = -2x + 2$

- 09dup3
3. Jessenia usually earns \$25 each week. Last week, she received an extra \$20 in bonus. What percent of her usual weekly income was her total income last week?
- A. 10%
 - B. 45%
 - C. 80%
 - D. 180%
 - E. 225%

- 09dup4
4. Let $M' = (12, 12)$ and $N' = (24, 12)$. If $\overline{M'N'}$ is the dilated image of \overline{MN} , where $M = (5, 5)$, what are the coordinates of point N ?
- F. (17, 7)
 - G. (10, 5)
 - H. (7.5, 5)
 - J. (0.2, 0.1)
 - K. (0.1, 0.2)

- 09dup5
5. n is an integer smaller than -2 . What is the range of possible values of $\frac{1}{n^2}$?
- A. $\frac{1}{n^2} < -4$
 - B. $\frac{1}{n^2} > 4$
 - C. $0 < \frac{1}{n^2} < \frac{1}{4}$
 - D. $-\frac{1}{4} < \frac{1}{n^2} < 0$
 - E. $-\frac{1}{2} < \frac{1}{n^2} < \frac{1}{2}$

6. 09dup6

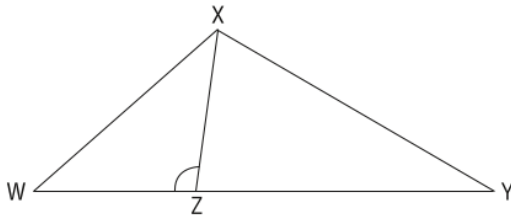

\overline{WZY} is a straight line segment and $\triangle XWZ$ is congruent to $\triangle YXZ$. What can one conclude about $\angle XZW$? (The figure is not drawn to scale.)

- F. $\angle XZW$ is a right angle.
- G. $\angle XZW$ is larger than $\angle XZY$.
- H. $\angle XZW$ is smaller than $\angle XZY$.
- J. $\angle XZW$ has the same measure as $\angle XYZ$.
- K. $\angle XZW$ has the same measure as $\angle YXZ$.

7. Simplify $\frac{e^2 \cdot e^3}{e^6}$ 09dup7

- A. 1
- B. e^0
- C. e^{-1}
- D. $e^{\frac{5}{6}}$
- E. e

8. 09dup8

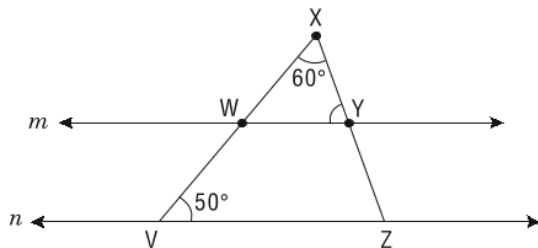

line $m \parallel$ line n

\overline{VWX} is a straight line segment, and W and Y are points on line m . What is the measure of $\angle XYW$?

- F. 40°
- G. 50°
- H. 60°
- J. 70°
- K. 80°

9. 09dup9

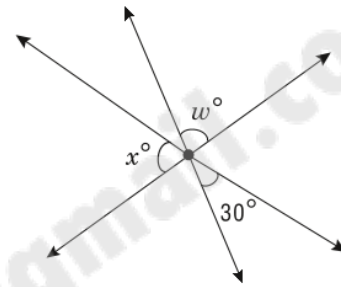

In the figure above, three lines intersect at a point. What is the value of w in terms of x ?

- A. $150 - x$
- B. $165 - x$
- C. $180 - x$
- D. $150 - 2x$
- E. $30 + x$

10. 09dup10

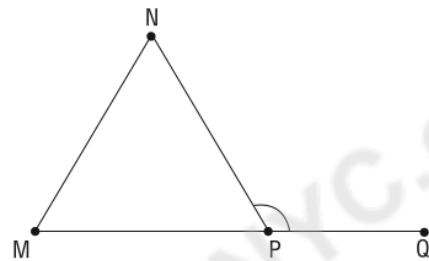

In this figure, $MN = NP = PM$ and \overline{MPQ} is a straight line segment. What is the measure of $\angle NPQ$?

- F. 60°
- G. 90°
- H. 100°
- J. 120°
- K. 150°

11. 09dup11

Let $P = (2, 3)$. First, translate P one unit to the right and call the image R. Next, reflect R over the y -axis and call the image S. Finally, rotate S 90° clockwise about the origin and call the image T. What are the coordinates of T?

- A. $(-3, -3)$
- B. $(-2, -3)$
- C. $(-2, 3)$
- D. $(3, -3)$
- E. $(3, 3)$

09dup12

12. The radius of circle C_1 is R , and that of circle C_2 is r . The area of C_1 is twice that of C_2 . What is R in terms of r ?

- F. $\frac{1}{2}r$
 G. $\frac{1}{\sqrt{2}}r$
 H. $\sqrt{2}r$
 J. $2r$
 K. $4r$

13.

09dup13

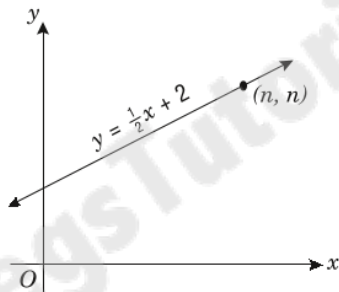

What is the value of n in the figure above?

- A. 1
 B. 2
 C. $2\frac{1}{2}$
 D. 3
 E. 4

09dup14

14.

$$\begin{aligned}x^2 &= P \\x^2 \cdot x &= Q \\x^2 \div x &= R \\x^2 + x &= S \\x^2 - x &= T\end{aligned}$$

If $x = -6$ in the equations above, which letter has the greatest value?

- F. P
 G. Q
 H. R
 J. S
 K. T

09dup15

15.

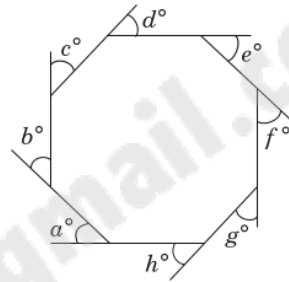

The figure above is a regular octagon. What is the sum of the measures of the exterior angles ($a + b + c + d + e + f + g + h$)?

- A. 30
 B. 45
 C. 135
 D. 360
 E. 1,080

09dup16

16.

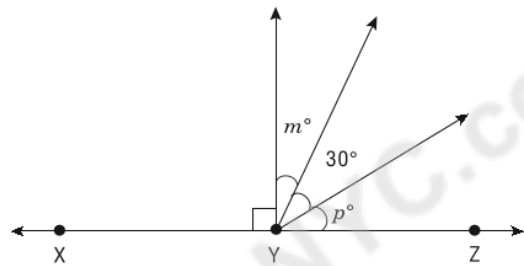

In the figure above, Y is a point on line \overleftrightarrow{XZ} . What is the value of $m + p$?

- F. 45
 G. 60
 H. 75
 J. 90
 K. 120

09dup17

17.

A jar contains exactly 6 balls: 5 red and 1 blue. If 5 balls are drawn from the jar at random and without replacement, what is the probability that they are all red?

- A. $\frac{1}{6}$
 B. $\frac{1}{5}$
 C. $\frac{5}{11}$
 D. $\frac{2}{3}$
 E. $\frac{5}{6}$

DIRECTIONS: This section provides sample mathematics problems for the Grade 9 test forms. These problems are based on material included in the New York City curriculum for Grade 8. (The Grade 8 problems on sample forms A and B cover mathematics material through Grade 7.) General directions for how to answer math questions are located on pages 48 and 86. There is no sample answer sheet for this section; mark your answers directly on this page or on a separate piece of paper.

$$\frac{9}{3} = 3 \quad \frac{3(9-15)}{4} = \frac{27-45}{4} = \frac{12}{4} = 3 \quad 3=3 \checkmark$$

1. If $\frac{x}{3} = \frac{3x-15}{4}$, what is the value of x ?

A. 9
B. $\frac{15}{2}$
C. $\frac{45}{13}$
D. 3
E. -9

$L.C.M(3,4) = 12$
 $12 \left(\frac{x}{3} = \frac{3x-15}{4} \right) =$
 $= 4x = 3(3x-15)$
 $4x = 9x - 45$
 $4x + 45 = 9x - 45$
 $4x + 45 = 9x - 45$
 $-4x + 45 = 5x - 45$
 $45 + 45 = 5x - 45 + 45$
 $90 = 5x \therefore x = 18$

- 2.

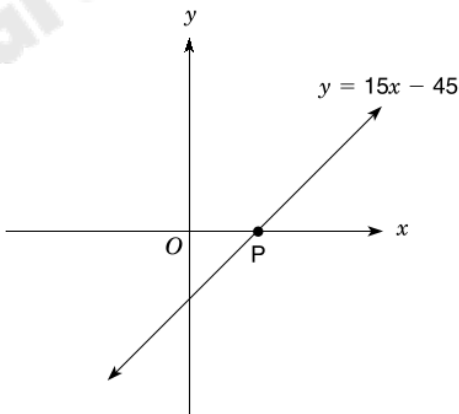

The line defined by the equation $y = 15x - 45$ intercepts the x -axis at point P as shown above. What are the coordinates of point P ?

- F. (45, 0)
G. (3, 0)
H. (-3, 0)
J. (0, -3)
K. (0, -45)

$0 = 15x - 45$
 $+45$
 $45 = 15x$
 $\frac{45}{15} = \frac{15x}{15}$
 $3 = x$

CHECK
 $15(3) - 45 = 0$
 $45 - 45 = 0$

3. How many different ways can a team of 2 men and 2 women be formed if there are 4 men and 5 women from which to select?

- A. 4
B. 6
C. 16
D. 60
E. 240
- $\frac{4}{M1} \frac{3}{M2} \frac{5}{W1} \frac{4}{W2}$
 $4 \times 3 = 12 \quad 12 \times 2 = 6 \quad 6 \times 11 = 60$
 $5 \times 4 = 20 \quad 20 \times 3 = 60$

- 4.

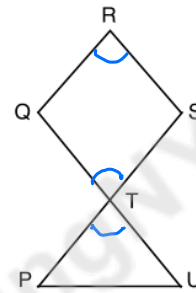

In the figure above, $\angle QTS$ is congruent to $\angle QRS$. Point T lies at the intersection of line segments \overline{QU} and \overline{PS} . Which of the following angles must also be congruent to $\angle QRS$?

- F. $\angle RST$
G. $\angle PTQ$
H. $\angle TUP$
J. $\angle TPU$
K. $\angle PTU$

5. If $(4^3)(8^2) = 2^x$, what is the value of x ?

A. 12
B. 10
C. 7
D. 6
E. 5

$(2^2)^3 (2^3)^2$
 $2^6 \cdot 2^6 = 2^x$
 $2^{12} = 2^x$

6. If $N = 1.\overline{25}$, what is the value of N expressed as a fraction?

F. $\frac{5}{4}$

G. $\frac{124}{99}$

H. $\frac{113}{90}$

J. $\frac{125}{99}$

K. $\frac{14}{11}$

$1.\overline{25} = \frac{124}{99}$

7. If 1 liter is approximately equal to 1.06 quarts and 32 ounces equals 1 quart, how many 20-ounce containers of soda can be **completely** filled by a 2-liter container of soda?

- A. 2
- B.** 3
- C. 4
- D. 5
- E. 6

$1L = 1.06 \times 32oz = 1.06 \times 32oz$
 $2L = 1.06 \times 32 \times 2$
 $\frac{1.06 \times 32 \times 2}{20} = 1.06 \times 32$

$1.06 \times 32 = 33.92$
 $33.92 \div 20 = 1.698$
3

8.

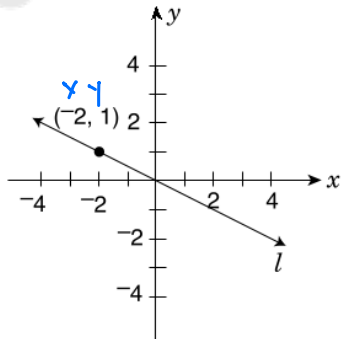

In the figure above, line l passes through the origin. Which equation below describes line l ?

F. $y = 2x$

G. $y = -2x$

H. $y = x$

J. $y = \frac{1}{2}x$

K. $y = -\frac{1}{2}x$

9. What is the simplified form of $\frac{6(2x^2 - 4x)}{3x}$ if $x \neq 0$?

A. $4x - 4$

B. $4x^2 - \frac{8}{3}$

C. $4x - 8$

D. $4x^2 - 8$

E. $4x^2 - 8x$

$\frac{4x^2 - 8x}{x} = 4x - 8$

10. The translation of point $P(3, 5)$ to $P'(5, -3)$ is equivalent to rotating point P by which of the following clockwise rotations about the origin?

F. 45°

G. 90°

H. 135°

J. 180°

K. 225°

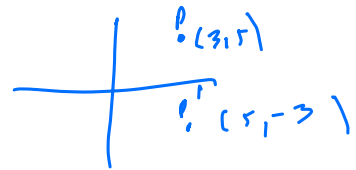

11. What is the greatest integer n that satisfies the inequality $5 - n \geq 3n - 4$?

A. 1

B. 2

C. $2\frac{1}{4}$

D. 3

E. 4

$5 - n \geq 3n - 4$
 $5 + 4 \geq 4n - 4$
 $9 \geq 4n - 4$
 $13 \geq 4n$
 $2\frac{3}{4} \geq n$

12. The volume of a cube is 729 cubic feet. What is the length, in **inches**, of one side of this cube?

F. $\frac{3}{4}$ in.

G. 9 in.

H. 108 in.

J. 243 in.

K. 2,916 in.

$81 \times 9 = 729$
 $9^3 = 729$
108 in

13.

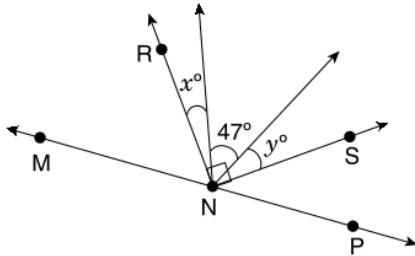

In the figure above, point N lies on straight line \overleftrightarrow{MNP} , and $\angle RNS$ is a right angle. What is the value of y in terms of x ?

- A. $43 - x$
 B. $x - 43$
 C. $133 - x$
 D. $x - 133$
 E. x
- $x + 47 + y = 90$
 $y = 90 - x - 47$
 $= 43 - x$

14. A property is valued at \$300,000 today. If this represents a 150% increase in value over its value 10 years ago, what was the value of this property 10 years ago?

- F. \$120,000
 G. \$150,000
 H. \$200,000
 J. \$275,000
 K. \$450,000
- $300,000 = 250\%$
 $300,000 = \frac{250}{100} \text{OV}$
 $\text{OV} = 300,000 \times \frac{100}{250}$
 $= \frac{300,000}{2.5} = 120,000$

15.

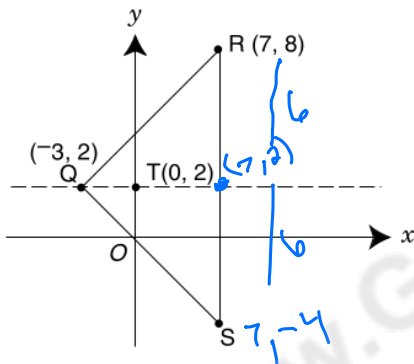

The dashed line is the line of symmetry for triangle QRS. What are the coordinates of point S?

- A. $(-7, -8)$
 B. $(7, -8)$
 C. $(7, -4)$
 D. $(-7, -4)$
 E. $(7, 8)$

16.

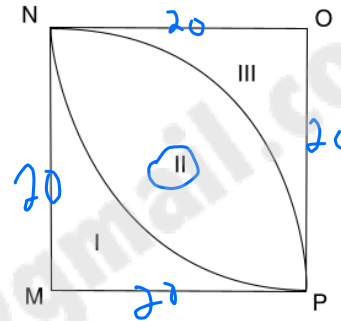

In the figure above, MNOP is a square with sides of length 20. Each arc inside MNOP is $\frac{1}{4}$ of the circumference of a circle with either M or O as its center. What is the area of the region labeled II? Express your answer in terms of π .

- F. 50π
 G. 100π
 H. $200\pi - 100$
 J. $200\pi - 400$
 K. $800\pi - 400$
- $A_{III} = A_S - \frac{A_C}{4} = 400 - \frac{\pi \cdot 20^2}{4}$
 $= 400 - 400\pi = 400 - 100\pi$
 $A_{II} = A_S - 2A_{III}$
 $= 400 - (800 - 200\pi)$

17.

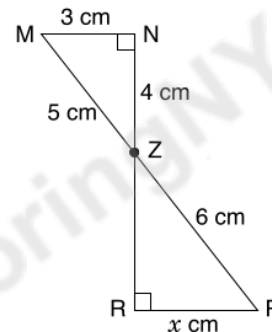

In the figure above, all lines are straight. \overline{MP} and \overline{RN} intersect at point Z. What is the value of x ?

- A. 3
 B. $3\frac{3}{5}$
 C. 4
 D. $4\frac{4}{5}$
 E. 5

$\frac{3}{5} = \frac{x}{6}$
 $\frac{18}{5} = \frac{5x}{5}$
 $3\frac{3}{5} = x$

DIRECTIONS: This section provides sample mathematics problems for the Grade 9 test forms. These problems are based on material included in the New York City curriculum for Grade 8. (The Grade 8 problems on sample forms A and B cover mathematics material through Grade 7.) General directions for how to answer math questions are located on pages 48 and 86. There is no sample answer sheet for this section; mark your answers directly on this page or on a separate piece of paper.

1. If $\frac{x}{3} = \frac{3x - 15}{4}$, what is the value of x ? 12dup1
- A. 9
- B. $\frac{15}{2}$
- C. $\frac{45}{13}$
- D. 3
- E. -9

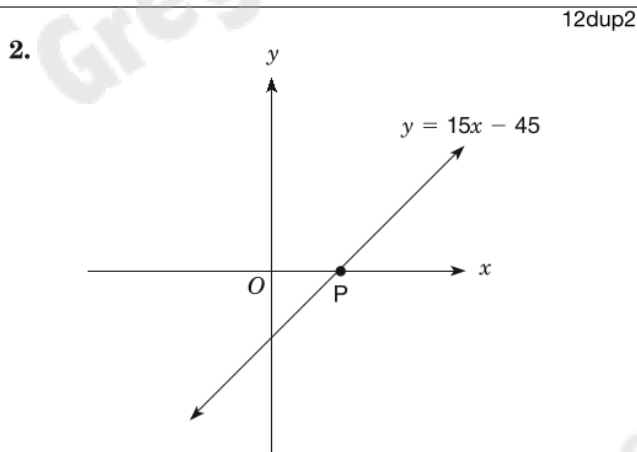

The line defined by the equation $y = 15x - 45$ intercepts the x -axis at point P as shown above. What are the coordinates of point P?

- F. (45, 0)
- G. (3, 0)
- H. (-3, 0)
- J. (0, -3)
- K. (0, -45)

3. How many different ways can a team of 2 men and 2 women be formed if there are 4 men and 5 women from which to select? 12dup3
- A. 4
- B. 6
- C. 16
- D. 60
- E. 240

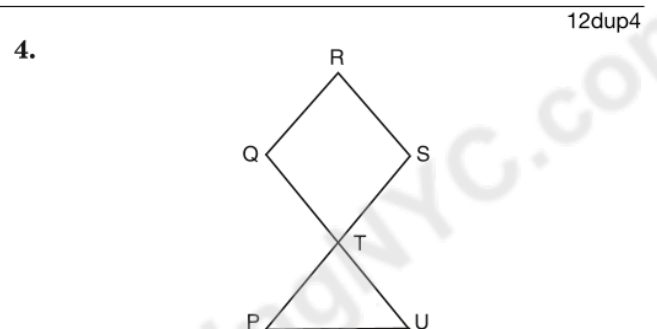

In the figure above, $\angle QTS$ is congruent to $\angle QRS$. Point T lies at the intersection of line segments \overline{QU} and \overline{PS} . Which of the following angles must also be congruent to $\angle QRS$?

- F. $\angle RST$
- G. $\angle PTQ$
- H. $\angle TUP$
- J. $\angle TPU$
- K. $\angle PTU$

5. If $(4^3)(8^2) = 2^x$, what is the value of x ? 12dup5
- A. 12
- B. 10
- C. 7
- D. 6
- E. 5

- 12dup6
6. If $N = 1.\overline{25}$, what is the value of N expressed as a fraction?
- F. $\frac{5}{4}$
- G. $\frac{124}{99}$
- H. $\frac{113}{90}$
- J. $\frac{125}{99}$
- K. $\frac{14}{11}$

- 12dup7
7. If 1 liter is approximately equal to 1.06 quarts and 32 ounces equals 1 quart, how many 20-ounce containers of soda can be **completely** filled by a 2-liter container of soda?
- A. 2
- B. 3
- C. 4
- D. 5
- E. 6

- 12dup8
- 8.

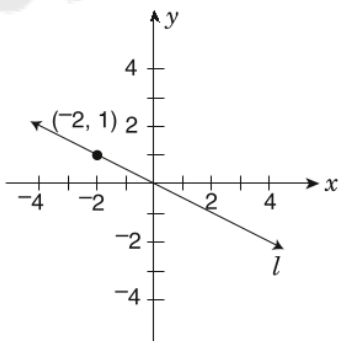

In the figure above, line l passes through the origin. Which equation below describes line l ?

- F. $y = 2x$
- G. $y = -2x$
- H. $y = x$
- J. $y = \frac{1}{2}x$
- K. $y = -\frac{1}{2}x$

- 12dup9
9. What is the simplified form of $\frac{6(2x^2 - 4x)}{3x}$ if $x \neq 0$?
- A. $4x - 4$
- B. $4x^2 - \frac{8}{3}$
- C. $4x - 8$
- D. $4x^2 - 8$
- E. $4x^2 - 8x$

- 12dup10
10. The translation of point $P(3, 5)$ to $P'(5, -3)$ is equivalent to rotating point P by which of the following clockwise rotations about the origin?
- F. 45°
- G. 90°
- H. 135°
- J. 180°
- K. 225°

- 12dup11
11. What is the greatest integer n that satisfies the inequality $5 - n \geq 3n - 4$?
- A. 1
- B. 2
- C. $2\frac{1}{4}$
- D. 3
- E. 4

- 12dup12
12. The volume of a cube is 729 cubic feet. What is the length, in **inches**, of one side of this cube?
- F. $\frac{3}{4}$ in.
- G. 9 in.
- H. 108 in.
- J. 243 in.
- K. 2,916 in.

12dup13

13.

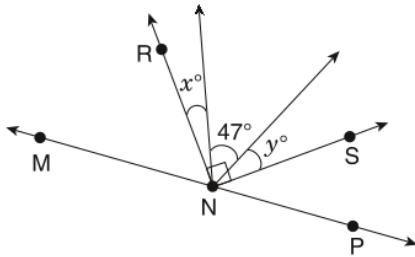

In the figure above, point N lies on straight line \overleftrightarrow{MNP} , and $\angle RNS$ is a right angle. What is the value of y in terms of x ?

- A. $43 - x$
- B. $x - 43$
- C. $133 - x$
- D. $x - 133$
- E. x

12dup14

14. A property is valued at \$300,000 today. If this represents a 150% increase in value over its value 10 years ago, what was the value of this property 10 years ago?

- F. \$120,000
- G. \$150,000
- H. \$200,000
- J. \$275,000
- K. \$450,000

12dup15

15.

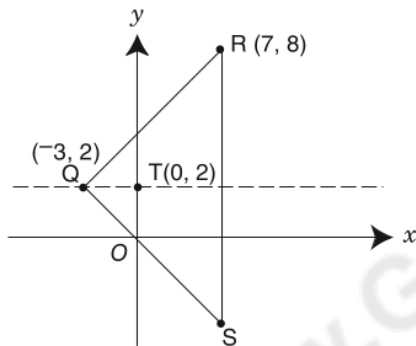

The dashed line is the line of symmetry for triangle QRS . What are the coordinates of point S ?

- A. $(-7, -8)$
- B. $(7, -8)$
- C. $(7, -4)$
- D. $(-7, -4)$
- E. $(7, 8)$

12dup16

16.

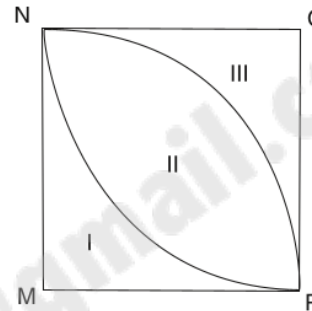

In the figure above, $MNOP$ is a square with sides of length 20. Each arc inside $MNOP$ is $\frac{1}{4}$ of the circumference of a circle with either M or O as its center. What is the area of the region labeled II? Express your answer in terms of π .

- F. 50π
- G. 100π
- H. $200\pi - 100$
- J. $200\pi - 400$
- K. $800\pi - 400$

12dup17

17.

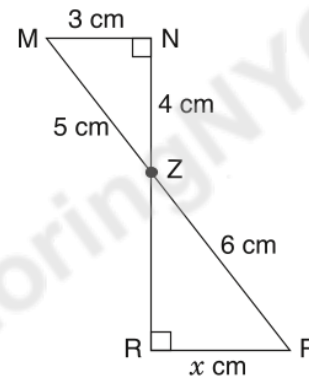

In the figure above, all lines are straight. \overline{MP} and \overline{RN} intersect at point Z . What is the value of x ?

- A. 3
- B. $3\frac{3}{5}$
- C. 4
- D. $4\frac{4}{5}$
- E. 5

SAMPLE PROBLEMS FOR GRADE 9 MATHEMATICS

DIRECTIONS: This section provides sample mathematics problems for the Grade 9 test forms. These problems are based on material included in the New York City curriculum for Grade 8. (The Grade 8 problems on sample forms A and B cover mathematics material through Grade 7.) General directions for how to answer math questions are located on pages 48 and 86. There is no sample answer sheet for this section; mark your answers directly on this page or on a separate piece of paper.

1.

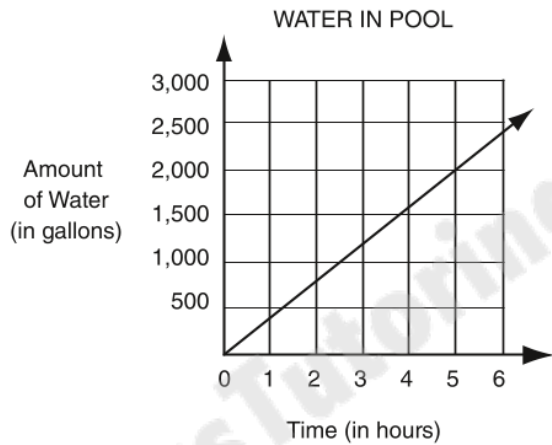

A swimming pool is being filled with water at a constant rate. The figure above is a portion of a graph that shows how the number of gallons of water in the pool changes over time. Starting with an empty pool, at the end of hour 5 there are 2,000 gallons in the pool. If the pool continues to fill at this rate, how much water will be in the pool at the end of hour 20? (Assume that the pool holds a total of 100,000 gallons.)

- A. 5,600 gal.
 - B. 6,000 gal.
 - C. 8,000 gal.**
 - D. 40,000 gal.
 - E. 80,000 gal.
- f: 5/2000 * 4 = 8000*

2. Define the operation \square as follows:

$$a \square \left(\frac{b}{c}\right) = \frac{a}{\left(\frac{b}{c}\right)}, \text{ where } b \text{ and } c \text{ are not zero.}$$

If $2 \square \left(\frac{4}{x}\right) = \frac{3}{2}$, what is the value of x ?

- F. 1
 - G. 2
 - H. 3**
 - J. 6
 - K. 12
- 2 / (4/x) = 3/2*
 $2 \cdot \frac{x}{4} = \frac{3}{2}$
 $\frac{2x}{4} = \frac{3}{2}$
 $\frac{x}{2} = \frac{3}{2} \therefore x = 3$

3.

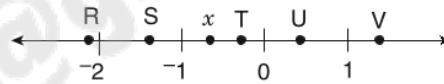

On the number line above, which letter could represent the location of x^2 ?

- A. R
 - B. S
 - C. T
 - D. U**
 - E. V
- x ≈ -1.2*
 $x^2 ≈ 1.44$

4.

$$7^{-2} + 7^{-1} + 7^0 = \frac{x}{49} =$$

What is the value of x in the equation above?

- F. 8
 - G. 9
 - H. 10
 - J. 57**
 - K. 58
- 1/7^2 + 1/7 + 1 = x/49*
 $\frac{1}{49} + \frac{7}{49} + \frac{49}{49} = \frac{x}{49}$
 $\frac{57}{49} = \frac{x}{49} \therefore x = 57$

5.

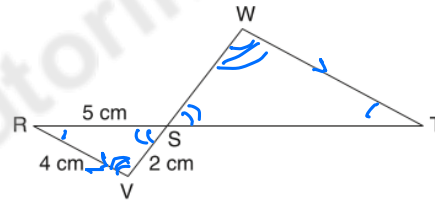

In the figure above, \overline{RST} and \overline{VSW} are straight line segments and \overline{WT} is parallel to \overline{RV} . What is $\frac{WT}{ST}$?

- A. $\frac{2}{5}$
 - B. $\frac{4}{5}$**
 - C. 1
 - D. $\frac{5}{4}$
 - E. 20
- RV/RS = WT/ST = 4/5*

$$1.26 \times 10^{19} - .011 \times 10^{19}$$

6. If $(12.6 \times 10^{18}) - (1.1 \times 10^{17}) = k \times 10^{19}$, what is the value of k ?

- F. 0.016
- G. 1.150
- H. 1.249**
- J. 11.500
- K. 16.000

$$\begin{array}{r} 1.26 \\ - .011 \\ \hline 1.249 \end{array}$$

7.

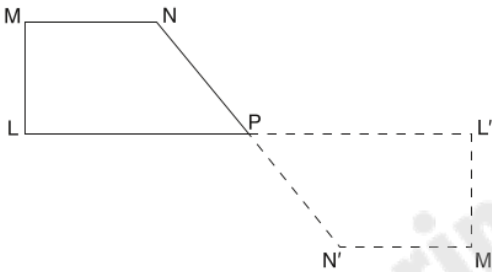

Ro: 2
Re: 3
TR: 4

A geometry game awards a different score for each geometric transformation. Each 90° rotation about a point will earn a score of 2, a reflection over a horizontal or vertical line will earn a score of 3, and a horizontal or vertical translation will earn a score of 4. Which set of transformations will earn the highest score to transform LMNP to L'M'N'P as shown above?

- A. two reflections** 6
- B. two translations 8 X
- C. two 90° rotations 4
- D. a translation, followed by a reflection 7 X
- E. a 90° rotation, followed by a reflection 5 X

8.

STUDENTS OWNING PETS

Number of Pets Owned	Number of Students
0	5
1	7
2	3
3	4
4	0
5	1

$$\begin{array}{r} 7 \\ 6 \\ 12 \\ 5 \\ \hline 30 \end{array}$$

There are 20 students in a class. The frequency table above shows the number of these students that own 0, 1, 2, 3, 4, or 5 pets. What is the mean number of pets owned per student in this class?

- F. $1\frac{1}{2}$**
- G. 3
- H. $3\frac{1}{3}$
- J. 4
- K. 5

$$\frac{30}{20} = 1.5$$

9. Let $(x, y) \rightarrow (x + 10, y - 10)$. Using that rule, if $(n, r) \rightarrow (100, 100)$, what is (n, r) ?

- A. (90, 90)
- B. (90, 110)**
- C. (100, 100)
- D. (110, 90)
- E. (110, 110)

$$90, 110$$

10. Raul has two containers. One is a cylinder with an inner radius of 4 inches and an inner height of 8 inches. The other is a cube with inner height, width, and length each equal to 8 inches. The cylinder is filled with water and the cube is empty. If Raul pours the contents of the cylinder into the cube, how deep will the water be in the cube?

- F. 2 in.
- G. $\frac{2}{3}\pi$ in.
- H. 4 in.
- J. 2π in.**
- K. 4π in.

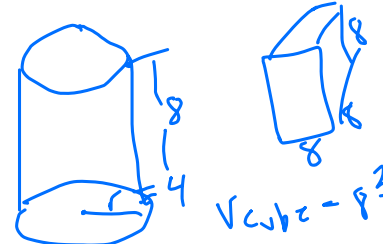

$$\begin{aligned} V_{\text{cyl}} &= \pi r^2 h \\ &= \pi (4^2)(8) \\ &= \pi (16)(8) \\ &= 128\pi \end{aligned}$$

$$\begin{aligned} V_{\text{cube}} &= s^3 \\ &= 8^3 \\ &= 512 \end{aligned}$$

$$\frac{128\pi}{512} = \frac{128\pi}{64} = 2\pi$$

11.

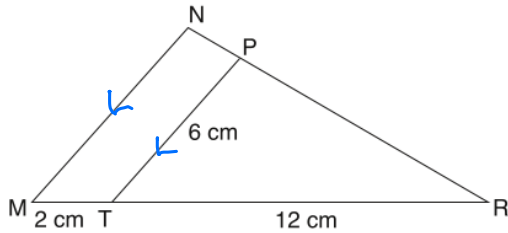

In the figure above, if \overline{MN} is parallel to \overline{TP} , what is the length of \overline{MN} ?

- A. 7 cm
 - B. 8 cm
 - C. 10 cm
 - D. 12 cm
 - E. 14 cm
- $\frac{6}{12} = \frac{MN}{12+2}$

12.

$|x - 1| < 3$
 $|x + 2| < 4$

$-2 < x < 4$ $-6 < x < 2$

How many integer values of x satisfy both inequalities shown above?

- F. 0
 - G. 1
 - H. 3
 - J. 4
 - K. 5
- $x - 1 < 3 \Rightarrow x < 4$
 $x + 2 < 4 \Rightarrow x < 2$
 $-(x - 1) < 3 \Rightarrow -x + 1 < 3 \Rightarrow -x < 2 \Rightarrow x > -2$
 $-(x + 2) < 4 \Rightarrow -x - 2 < 4 \Rightarrow -x < 6 \Rightarrow x > -6$

13.

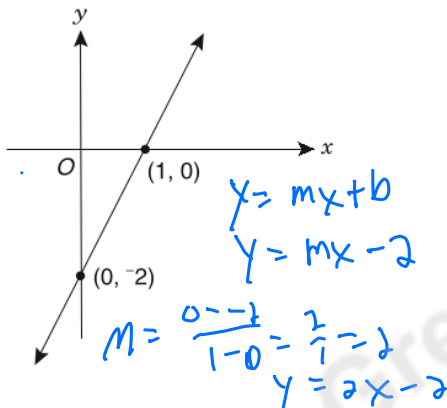

The straight line shown above is the graph of $y = f(x)$. Which of the following points satisfies the inequality $y > f(x)$?

- A. (-2, -7) $-7 > 2(-2) - 2 \Rightarrow -7 > -6$
- B. (-1, -3) $-3 > 2(-1) - 2 \Rightarrow -3 > -4$
- C. (1, 0) $0 > 2(1) - 2 \Rightarrow 0 > 0$
- D. (2, 1) $1 > 2(2) - 2 \Rightarrow 1 > 2$
- E. (3, 4) $4 > 2(3) - 2 \Rightarrow 4 > 4$

14.

$\frac{p}{q}, p + q, p - q, p^2 + q^2, \frac{p^2}{q^2}$

If $p = q = \frac{1}{\sqrt{2}}$, which one of the expressions above does not represent a rational number?

- F. $\frac{p}{q}$
- G. $p + q$
- H. $p - q$
- J. $p^2 + q^2$
- K. $\frac{p^2}{q^2}$

15.

Straight line k passes through the point $(-3, 4)$ with an x -intercept of 3. What is the equation of line k ?

- A. $y = -\frac{3}{2}x + 3$
- B. $y = -\frac{2}{3}x - 3$
- C. $y = -\frac{2}{3}x + 2$
- D. $y = -\frac{1}{3}x + 3$
- E. $y = \frac{2}{3}x - 2$

$(-3, 4)$
 $(3, 0)$
 $m = \frac{4 - 0}{-3 - 3} = \frac{4}{-6} = -\frac{2}{3}$
 $y = -\frac{2}{3}x + b$
 $0 = -\frac{2}{3}(3) + b \Rightarrow b = 2$
 $\therefore y = -\frac{2}{3}x + 2$

16.

Seven consecutive integers are arranged in increasing order. Their sum is $7k$. What is the value of the second integer in terms of k ?

- F. $k - 6$
- G. $k - 2$
- H. k
- J. $k + 1$
- K. $7k - 6$

$\frac{7k}{7} = k$ is the middle #
the 4th #

17.

A tiny robot sits on the point $(1, -2)$ of the coordinate plane. At each flash of a blue light, it moves 4 units to the right and 5 units down. At each flash of a red light, it moves 1 unit to the left and 4 units up. If, at the end of 15 red flashes and n blue flashes, the robot is sitting on the line $y = x$, what is n ?

- A. 5
- B. 8
- C. 14
- D. 15
- E. 44

$b: 4r, 5d$
 $r: 1L, 4u$
 $(-14, 58)$
 $-14 + 4n = 58 - 5n$
 $+14 \quad +5n \quad +4$
 $9n = 72 \Rightarrow n = 8$

SAMPLE PROBLEMS FOR GRADE 9 MATHEMATICS

DIRECTIONS: This section provides sample mathematics problems for the Grade 9 test forms. These problems are based on material included in the New York City curriculum for Grade 8. (The Grade 8 problems on sample forms A and B cover mathematics material through Grade 7.) General directions for how to answer math questions are located on pages 50 and 88. There is no sample answer sheet for this section; mark your answers directly on this page or on a separate piece of paper.

1. 14dup1

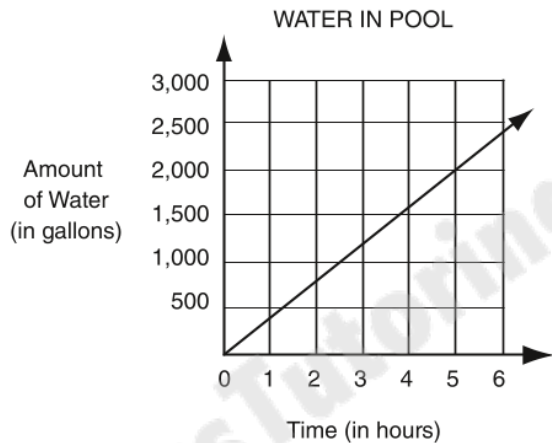

A swimming pool is being filled with water at a constant rate. The figure above is a portion of a graph that shows how the number of gallons of water in the pool changes over time. Starting with an empty pool, at the end of hour 5 there are 2,000 gallons in the pool. If the pool continues to fill at this rate, how much water will be in the pool at the end of hour 20? (Assume that the pool holds a total of 100,000 gallons.)

- A. 5,600 gal.
- B. 6,000 gal.
- C. 8,000 gal.
- D. 40,000 gal.
- E. 80,000 gal.

2. 14dup2
Define the operation \square as follows:

$$a \square \left(\frac{b}{c}\right) = \frac{a}{\left(\frac{b}{c}\right)}, \text{ where } b \text{ and } c \text{ are not zero.}$$

If $2 \square \left(\frac{4}{x}\right) = \frac{3}{2}$, what is the value of x ?

- F. 1
- G. 2
- H. 3
- J. 6
- K. 12

3. 14dup3

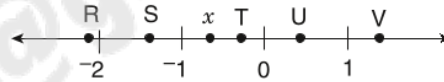

On the number line above, which letter could represent the location of x^2 ?

- A. R
- B. S
- C. T
- D. U
- E. V

4. 14dup4
$$7^{-2} + 7^{-1} + 7^0 = \frac{x}{49}$$

What is the value of x in the equation above?

- F. 8
- G. 9
- H. 10
- J. 57
- K. 58

5. 14dup5

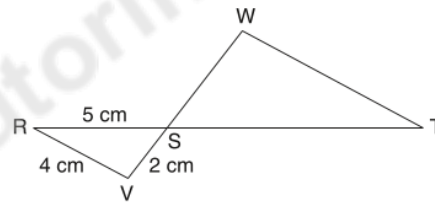

In the figure above, \overline{RST} and \overline{VSW} are straight line segments and \overline{WT} is parallel to \overline{RV} . What is $\frac{WT}{ST}$?

- A. $\frac{2}{5}$
- B. $\frac{4}{5}$
- C. 1
- D. $\frac{5}{4}$
- E. 20

- 14dup6
6. If $(12.6 \times 10^{18}) - (1.1 \times 10^{17}) = k \times 10^{19}$, what is the value of k ?
- F. 0.016
 G. 1.150
 H. 1.249
 J. 11.500
 K. 16.000

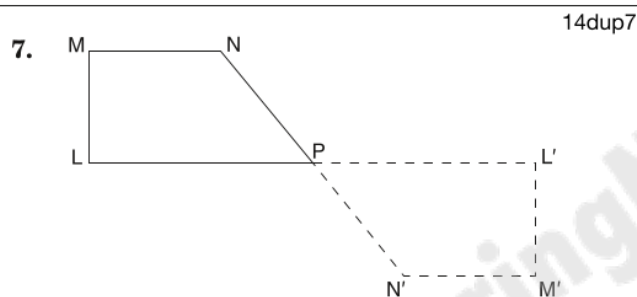

A geometry game awards a different score for each geometric transformation. Each 90° rotation about a point will earn a score of 2, a reflection over a horizontal or vertical line will earn a score of 3, and a horizontal or vertical translation will earn a score of 4. Which set of transformations would earn the highest score to transform LMNP to L'M'N'P as shown above?

- A. two reflections
 B. two translations
 C. two 90° rotations
 D. a translation, followed by a reflection
 E. a 90° rotation, followed by a reflection

14dup8

8. STUDENTS OWNING PETS

Number of Pets Owned	Number of Students
0	5
1	7
2	3
3	4
4	0
5	1

There are 20 students in a class. The frequency table above shows the number of these students that own 0, 1, 2, 3, 4, or 5 pets. What is the mean number of pets owned per student in this class?

- F. $1\frac{1}{2}$
 G. 3
 H. $3\frac{1}{3}$
 J. 4
 K. 5

- 14dup9
9. Let $(x, y) \rightarrow (x + 10, y - 10)$. Using that rule, if $(n, r) \rightarrow (100, 100)$, what is (n, r) ?
- A. (90, 90)
 B. (90, 110)
 C. (100, 100)
 D. (110, 90)
 E. (110, 110)

- 14dup10
10. Raul has two containers. One is a cylinder with an inner radius of 4 inches and an inner height of 8 inches. The other is a cube with inner height, width, and length each equal to 8 inches. The cylinder is filled with water and the cube is empty. If Raul pours the contents of the cylinder into the cube, how deep will the water be in the cube?
- F. 2 in.
 G. $\frac{2}{3}\pi$ in.
 H. 4 in.
 J. 2π in.
 K. 4π in.

11.

14dup11

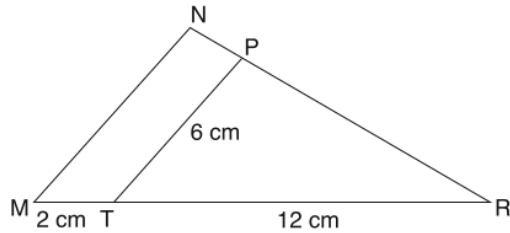

In the figure above, if \overline{MN} is parallel to \overline{TP} , what is the length of \overline{MN} ?

- A. 7 cm
- B. 8 cm
- C. 10 cm
- D. 12 cm
- E. 14 cm

12.

$$\begin{aligned} |x - 1| &< 3 \\ |x + 2| &< 4 \end{aligned}$$

14dup12

How many integer values of x satisfy both inequalities shown above?

- F. 0
- G. 1
- H. 3
- J. 4
- K. 5

13.

14dup13

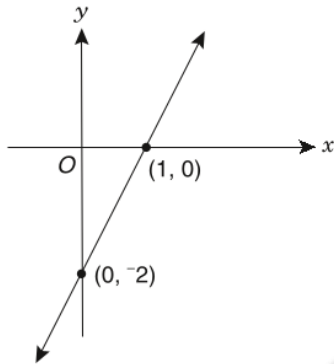

The straight line shown above is the graph of $y = f(x)$. Which of the following points satisfies the inequality $y > f(x)$?

- A. $(-2, -7)$
- B. $(-1, -3)$
- C. $(1, 0)$
- D. $(2, 1)$
- E. $(3, 4)$

14.

$$\frac{p}{q}, p + q, p - q, p^2 + q^2, \frac{p^2}{q^2}$$

14dup14

If $p = q = \frac{1}{\sqrt{2}}$, which one of the expressions above does **not** represent a rational number?

- F. $\frac{p}{q}$
- G. $p + q$
- H. $p - q$
- J. $p^2 + q^2$
- K. $\frac{p^2}{q^2}$

15.

Straight line k passes through the point $(-3, 4)$ with an x -intercept of 3. What is the equation of line k ?

14dup15

- A. $y = -\frac{3}{2}x + 3$
- B. $y = -\frac{2}{3}x - 3$
- C. $y = -\frac{2}{3}x + 2$
- D. $y = -\frac{1}{3}x + 3$
- E. $y = \frac{2}{3}x - 2$

16.

Seven consecutive integers are arranged in increasing order. Their sum is $7k$. What is the value of the second integer in terms of k ?

14dup16

- F. $k - 6$
- G. $k - 2$
- H. k
- J. $k + 1$
- K. $7k - 6$

17.

A tiny robot sits on the point $(1, -2)$ of the coordinate plane. At each flash of a blue light, it moves 4 units to the right and 5 units down. At each flash of a red light, it moves 1 unit to the left and 4 units up. If, at the end of 15 red flashes and n blue flashes, the robot is sitting on the line $y = x$, what is n ?

14dup17

- A. 5
- B. 8
- C. 14
- D. 15
- E. 44

SAMPLE PROBLEMS FOR GRADE 9 MATHEMATICS

GRADE

9

15-16

DIRECTIONS: This section provides sample mathematics problems for the Grade 9 test forms. These problems are based on material included in the New York City curriculum for Grade 8. (The Grade 8 problems on sample forms A and B cover mathematics material through Grade 7.) General directions for how to answer math questions are located on pages 50 and 88. There is no sample answer sheet for this section; mark your answers directly on this page or on a separate piece of paper.

1.

STUDENTS OWNING PETS

14dup8

Number of Pets Owned	Number of Students
0	5
1	7
2	3
3	4
4	0
5	1

There are 20 students in a class. The frequency table above shows the number of these students that own 0, 1, 2, 3, 4, or 5 pets. What is the mean number of pets owned per student in this class?

- A. $1\frac{1}{2}$
- B. 3
- C. $3\frac{1}{3}$
- D. 4
- E. 5

2.

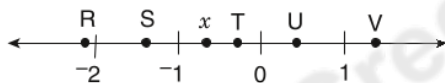

14dup3

On the number line above, which letter could represent the location of x^2 ?

- F. R
- G. S
- H. T
- J. U
- K. V

3. Define the operation \square as follows:

14dup2

$$a \square \left(\frac{b}{c}\right) = \frac{a}{\left(\frac{b}{c}\right)}, \text{ where } b \text{ and } c \text{ are not zero.}$$

$$\text{If } 2 \square \left(\frac{4}{x}\right) = \frac{3}{2}, \text{ what is the value of } x?$$

- A. 1
- B. 2
- C. 3
- D. 6
- E. 12

4. If $(4^3)(8^2) = 2^x$, what is the value of x ?

12dup5

- F. 12
- G. 10
- H. 7
- J. 6
- K. 5

5.

12dup15

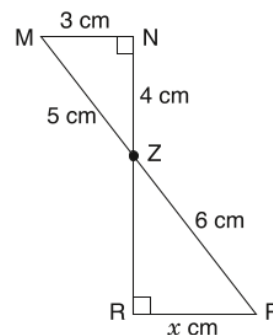

In the figure above, all lines are straight. \overline{MP} and \overline{RN} intersect at point Z. What is the value of x ?

- A. 3
- B. $3\frac{3}{5}$
- C. 4
- D. $4\frac{4}{5}$
- E. 5

- 14dup10
6. Raul has two containers. One is a cylinder with an inner radius of 4 inches and an inner height of 8 inches. The other is a cube with inner height, width, and length each equal to 8 inches. The cylinder is filled with water and the cube is empty. If Raul pours the contents of the cylinder into the cube, how deep will the water be in the cube?
- F. 2 in.
 G. $\frac{2}{3}\pi$ in.
 H. 4 in.
 J. 2π in.
 K. 4π in.

- 12dup10
7. The translation of point P (3, 5) to P' (5, -3) is equivalent to rotating point P by which of the following clockwise rotations about the origin?
- A. 45°
 B. 90°
 C. 135°
 D. 180°
 E. 225°

- 14dup6
8. If $(12.6 \times 10^{18}) - (1.1 \times 10^{17}) = k \times 10^{19}$, what is the value of k ?
- F. 0.016
 G. 1.150
 H. 1.249
 J. 11.500
 K. 16.000

- 14dup1
- 9.

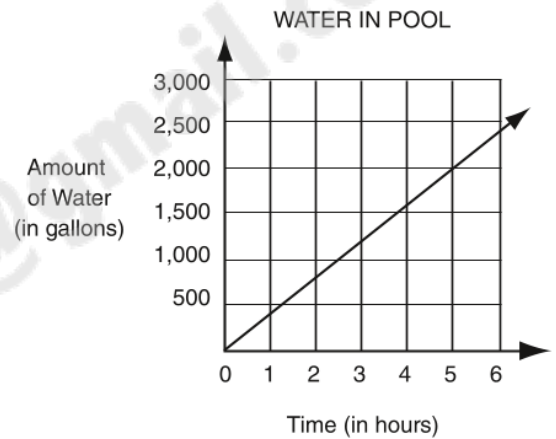

A swimming pool is being filled with water at a constant rate. The figure above is a portion of a graph that shows how the number of gallons of water in the pool changes over time. Starting with an empty pool, at the end of hour 5 there are 2,000 gallons in the pool. If the pool continues to fill at this rate, how much water will be in the pool at the end of hour 20? (Assume that the pool holds a total of 100,000 gallons.)

- A. 5,600 gal.
 B. 6,000 gal.
 C. 8,000 gal.
 D. 40,000 gal.
 E. 80,000 gal.
- 14dup9
10. Let $(x, y) \rightarrow (x + 10, y - 10)$. Using that rule, if $(n, r) \rightarrow (100, 100)$, what is (n, r) ?
- F. (90, 90)
 G. (90, 110)
 H. (100, 100)
 J. (110, 90)
 K. (110, 110)

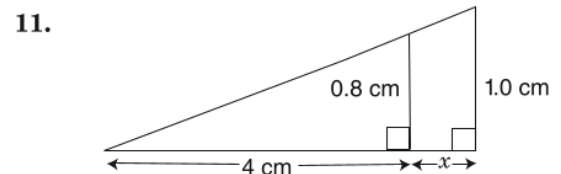

- In the figure above, what is the value of x ?
- A. 1 cm
 B. 1.2 cm
 C. 3.2 cm
 D. 4 cm
 E. 5 cm

12. Straight line k passes through the point $(-3, 4)$ with an x -intercept of 3. What is the equation of line k ? 14dup15

- F. $y = -\frac{3}{2}x + 3$
 G. $y = -\frac{2}{3}x - 3$
 H. $y = -\frac{2}{3}x + 2$
 J. $y = -\frac{1}{3}x + 3$
 K. $y = \frac{2}{3}x - 2$

13. 12dup2

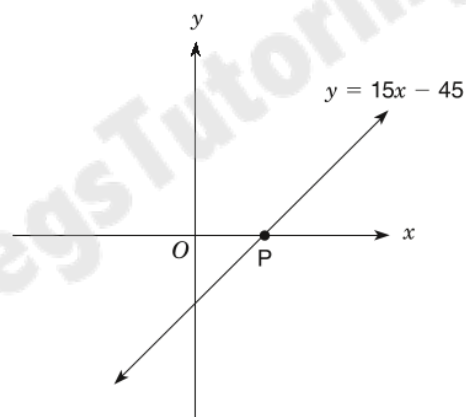

The line defined by the equation $y = 15x - 45$ intercepts the x -axis at point P as shown above. What are the coordinates of point P?

- A. $(45, 0)$
 B. $(3, 0)$
 C. $(-3, 0)$
 D. $(0, -3)$
 E. $(0, -45)$
14. Seven consecutive integers are arranged in increasing order. Their sum is $7k$. What is the value of the second integer in terms of k ? 14dup16
- F. $k - 6$
 G. $k - 2$
 H. k
 J. $k + 1$
 K. $7k - 6$

15. $\frac{p}{q}, p + q, p - q, p^2 + q^2, \frac{p^2}{q^2}$ 14dup14

If $p = q = \frac{1}{\sqrt{2}}$, which one of the expressions above does **not** represent a rational number?

- A. $\frac{p}{q}$
 B. $p + q$
 C. $p - q$
 D. $p^2 + q^2$
 E. $\frac{p^2}{q^2}$

16. A tiny robot sits on the point $(1, -2)$ of the coordinate plane. At each flash of a blue light, it moves 4 units to the right and 5 units down. At each flash of a red light, it moves 1 unit to the left and 4 units up. If, at the end of 15 red flashes and n blue flashes, the robot is sitting on the line $y = x$, what is n ? 14dup17

- F. 5
 G. 8
 H. 14
 J. 15
 K. 44

17. $|x - 1| < 3$
 $|x + 2| < 4$ 14dup12

How many integer values of x satisfy both inequalities shown above?

- A. 0
 B. 1
 C. 3
 D. 4
 E. 5

SAMPLE PROBLEMS FOR GRADE 9 MATHEMATICS

GRADE

9
16-17

DIRECTIONS: This section provides sample mathematics problems for the Grade 9 test forms. These problems are based on material included in the New York City curriculum for Grade 8. (The Grade 8 problems on sample forms A and B cover mathematics material through Grade 7.) General directions for how to answer math questions are located on pages 52 and 90. There is no sample answer sheet for this section; mark your answers directly on this page or on a separate piece of paper.

1. 12dup17

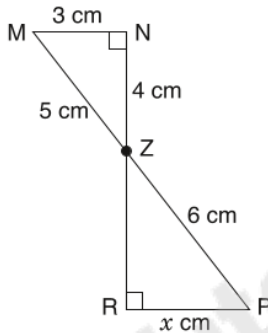

In the figure above, all lines are straight. \overline{MP} and \overline{RN} intersect at point Z. What is the value of x ?

- A. 3
- B. $3\frac{3}{5}$
- C. 4
- D. $4\frac{4}{5}$
- E. 5

2. 12dup10
The translation of point P (3, 5) to P' (5, -3) is equivalent to rotating point P by which of the following clockwise rotations about the origin?

- F. 45°
- G. 90°
- H. 135°
- J. 180°
- K. 225°

3. 14dup1

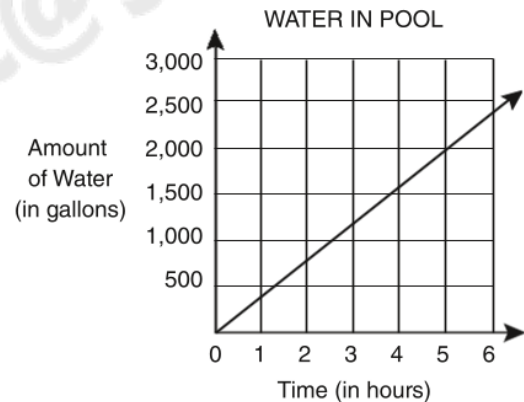

A swimming pool is being filled with water at a constant rate. The figure above is a portion of a graph that shows how the number of gallons of water in the pool changes over time. Starting with an empty pool, at the end of hour 5 there are 2,000 gallons in the pool. If the pool continues to fill at this rate, how much water will be in the pool at the end of hour 20? (Assume that the pool holds a total of 100,000 gallons.)

- A. 5,600 gal.
- B. 6,000 gal.
- C. 8,000 gal.
- D. 40,000 gal.
- E. 80,000 gal.

4. 12dup5
If $(4^3)(8^2) = 2^x$, what is the value of x ?

- F. 12
- G. 10
- H. 7
- J. 6
- K. 5

5. 12dup2

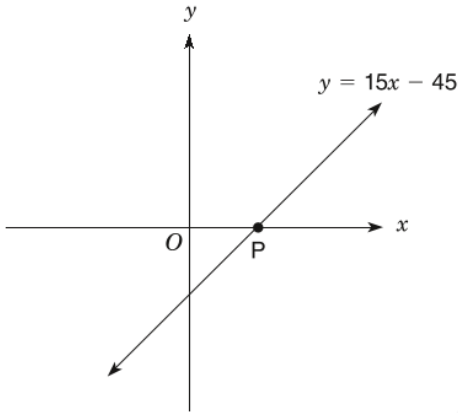

The line defined by the equation $y = 15x - 45$ intercepts the x -axis at point P as shown above. What are the coordinates of point P?

- A. (45, 0)
- B. (3, 0)
- C. (-3, 0)
- D. (0, -3)
- E. (0, -45)

6. 14dup3

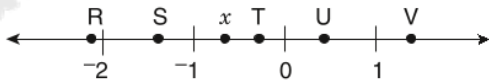

On the number line above, which letter could represent the location of x^2 ?

- F. R
- G. S
- H. T
- J. U
- K. V

7. 14dup6

If $(12.6 \times 10^{18}) - (1.1 \times 10^{17}) = k \times 10^{19}$, what is the value of k ?

- A. 0.016
- B. 1.150
- C. 1.249
- D. 11.500
- E. 16.000

8. 14dup8

STUDENTS OWNING PETS

Number of Pets Owned	Number of Students
0	5
1	7
2	3
3	4
4	0
5	1

There are 20 students in a class. The frequency table above shows the number of these students that own 0, 1, 2, 3, 4, or 5 pets. What is the mean number of pets owned per student in this class?

- F. $1\frac{1}{2}$
- G. 3
- H. $3\frac{1}{3}$
- J. 4
- K. 5

9. The temperature inside an oven when it is off is 60°F . When Gail turns the oven on, it heats at a constant rate, reaching a temperature of 350°F in 5 minutes. Which equation indicates the temperature (y) of the oven x minutes after it is turned on?

- A. $y = 5x + 60$
- B. $y = 60x + 350$
- C. $y = 58x + 60$
- D. $y = 70x + 60$
- E. $y = 350x + 58$

10. 14dup12

$$\begin{aligned} |x - 1| &< 3 \\ |x + 2| &< 4 \end{aligned}$$

How many integer values of x satisfy both inequalities shown above?

- F. 0
- G. 1
- H. 3
- J. 4
- K. 5

11. $\frac{p}{q}, p + q, p - q, p^2 + q^2, \frac{p^2}{q^2}$ 14dup14
- If $p = q = \frac{1}{\sqrt{2}}$, which one of the expressions above does **not** represent a rational number?
- A. $\frac{p}{q}$
 B. $p + q$
 C. $p - q$
 D. $p^2 + q^2$
 E. $\frac{p^2}{q^2}$

12. Let $(x, y) \rightarrow (x + 10, y - 10)$. Using that rule, if $(n, r) \rightarrow (100, 100)$, what is (n, r) ? 14dup9
- F. (90, 90)
 G. (90, 110)
 H. (100, 100)
 J. (110, 90)
 K. (110, 110)

13. Seven consecutive integers are arranged in increasing order. Their sum is $7k$. What is the value of the second integer in terms of k ? 14dup16
- A. $k - 6$
 B. $k - 2$
 C. k
 D. $k + 1$
 E. $7k - 6$

14. Define the operation \square as follows: 14dup2
- $$a \square \left(\frac{b}{c}\right) = \frac{a}{\left(\frac{b}{c}\right)}, \text{ where } b \text{ and } c \text{ are not zero.}$$
- If $2 \square \left(\frac{4}{x}\right) = \frac{3}{2}$, what is the value of x ?
- F. 1
 G. 2
 H. 3
 J. 6
 K. 12

15. Raul has two containers. One is a cylinder with an inner radius of 4 inches and an inner height of 8 inches. The other is a cube with inner height, width, and length each equal to 8 inches. The cylinder is filled with water and the cube is empty. If Raul pours the contents of the cylinder into the cube, how deep will the water be in the cube? 14dup10
- A. 2 in.
 B. $\frac{2}{3}\pi$ in.
 C. 4 in.
 D. 2π in.
 E. 4π in.

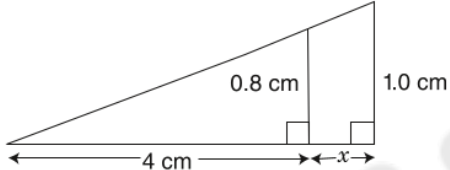
16. 16dup11
- 

In the figure above, what is the value of x ?

- F. 1 cm
 G. 1.2 cm
 H. 3.2 cm
 J. 4 cm
 K. 5 cm

17. Straight line k passes through the point $(-3, 4)$ with an x -intercept of 3. What is the equation of line k ? 14dup15
- A. $y = -\frac{3}{2}x + 3$
 B. $y = -\frac{2}{3}x - 3$
 C. $y = -\frac{2}{3}x + 2$
 D. $y = -\frac{1}{3}x + 3$
 E. $y = \frac{2}{3}x - 2$

SAMPLE PROBLEMS FOR GRADE 9 MATHEMATICS

DIRECTIONS: This section provides sample mathematics problems for the Grade 9 test forms. General directions for how to answer math questions are located on pages 61 and 114. There is no sample answer sheet for this section; mark your answers directly on this page or on a separate piece of paper.

1. Assume $S(x)$ equals the sum of all positive even integers less than or equal to x . What is the value of $S(7)$?

$$6 + 4 + 2 = 12$$

2. $\sqrt{16} \cdot \sqrt{196} =$

$$4 \cdot 14 = 56$$

- 3.

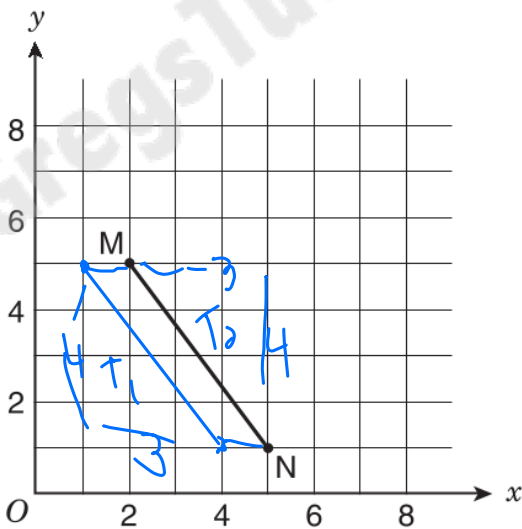

If \overline{MN} is translated 1 unit to the left to produce $M'N'$, what is the area of parallelogram $NMM'N'$?

- A. 3 square units
 B. 4 square units
 C. 5 square units
 D. 6 square units

$$A_s - A_{T_1} - A_{T_2} \\ 16 - 6 - 6 = 4$$

4. Simplify:

$$\frac{p^{12} \cdot p^0}{p^{-4}}$$

- E. 0
 F. p^{-3}
 G. p^8
 H. p^{16}

- 5.

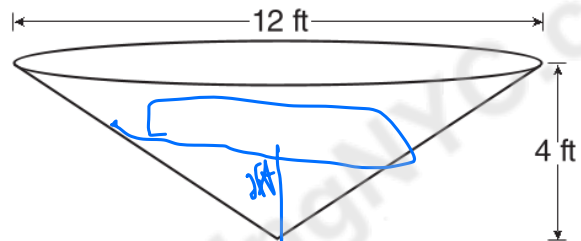

Water is pumped into a tank that is shaped like the right inverted cone shown above. The cone has a base diameter of 12 feet and a height of 4 feet. What is the volume, in cubic feet, of the water in the tank when the height of the water is 2 feet?

- A. 6π cu ft
 B. 18π cu ft
 C. 24π cu ft
 D. 48π cu ft

$$V = \frac{1}{3} \pi R^2 H \\ = \frac{1}{3} \pi 9 (2) \\ = 6\pi$$

6.

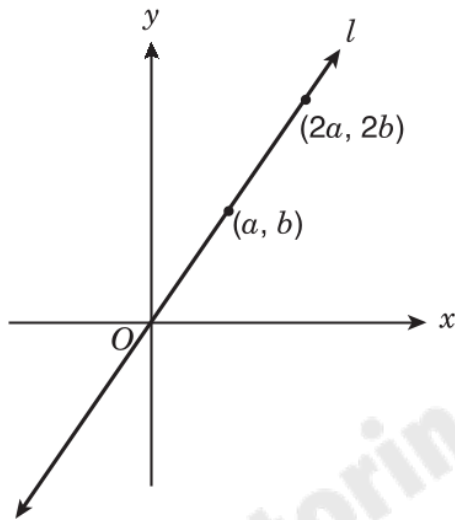

Straight line l passes through the origin, as shown in the figure above. What is the slope of line l in terms of a and b ?

- E. $\frac{a}{b}$
- F. $\frac{2b}{a}$
- G. $\frac{2a}{b}$
- H. $\frac{b}{a}$**

7. The graph shows the wolf population in Yellowstone National Park since 2000. A student drew a line of best fit to model the data.

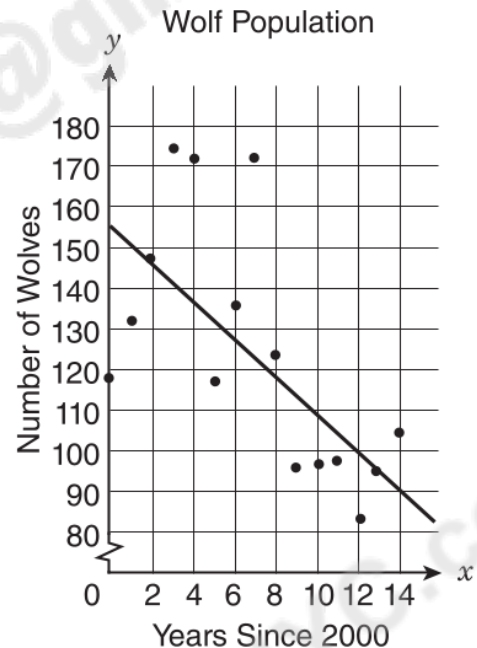

Which statement best describes the line of best fit that the student drew?

- A.** The line of best fit is not a strong model for the data, because the points are not close to the line.
- B. The line of best fit is not a strong model for the data, because it does not pass through any of the data points.
- C. The line of best fit is a strong model for the data, because both the line and the data show a negative trend.
- D. The line of best fit is a strong model for the data, because about half the data points are on each side of the line.

8. To determine the price of servicing a car, a mechanic charges a fixed fee plus an hourly rate for each hour he works. If his price for 4 hours of service is \$270, and his price for 7 hours of work is \$420, what is the fixed fee that the mechanic charges?

- E. \$50
- F. \$60
- G. \$70**
- H. \$120

$$\begin{aligned} 4r + ff &= 270 \\ 7r + ff &= 420 \\ \hline 3r &= 150 \\ r &= 50 \end{aligned}$$

$4(50) + ff = 270$
 $200 + ff = 270$
 $ff = 70$

9.

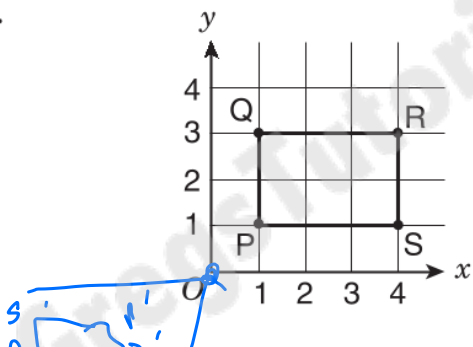

Rectangle PQRS above is rotated 180° about the origin to form rectangle $P'Q'R'S'$. What are the coordinates of R' ?

- A. $(4, -3)$
- B. $(-4, 3)$
- C. $(-4, 1)$
- D. $(-4, -3)$**

10.

$$\frac{15.3 \times 10^{-8}}{1.5 \times 10^4}$$

What is the quotient of the expression above, expressed in scientific notation?

- E. 1.02×10^{-13}
- F. 1.02×10^{-11}**
- G. 1.02×10^{-4}
- H. 1.02×10^{12}

$$10.2 \times 10^{-12}$$

11. Which of the following expressions is **negative** in value?

- A. $4 - \pi$ +
- B. $3\pi - 9$ +
- C. $12 - 4\pi$ -**
- D. $36 - 9\pi$ 1

12.

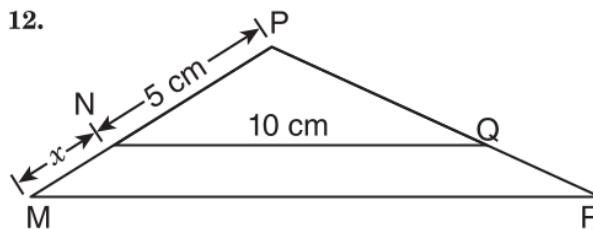

In the figure above, $\triangle MPR$ is similar to $\triangle NPQ$. If the length of \overline{NQ} is 10 centimeters, what is the length of \overline{MR} in terms of x ?

- E. $2x$
- F. $2x + 10$**
- G. $x + 5$
- H. $\frac{1}{2}x + 5$

$$\frac{15}{2\pi} = \frac{5+x}{MR}$$

$$10 + 2x = MR$$

13.

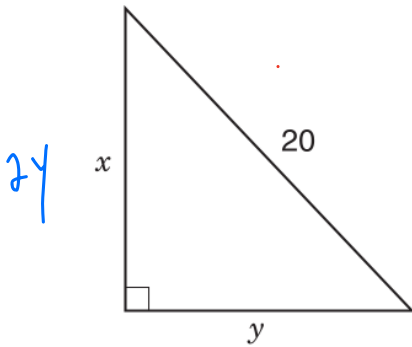

In the right triangle above, $x = 2y$. What is the value of y ?

- A. 2
- B. $\sqrt{10}$
- C. $\sqrt{80}$
- D. $\sqrt{200}$

$$\begin{aligned} (2y)^2 + y^2 &= 20^2 \\ 4y^2 + y^2 &= 400 \\ 5y^2 &= 400 \\ y^2 &= 80 \\ y &= \sqrt{80} \end{aligned}$$

SAMPLE QUESTIONS FOR GRADE 9 MATHEMATICS

DIRECTIONS: This section provides sample mathematics questions for the Grade 9 test forms. General directions for how to answer math questions are located on pages 81 and 152. There is no sample answer sheet for this section; mark your answers directly on this page or on a separate piece of paper.

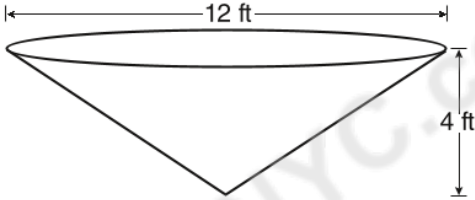
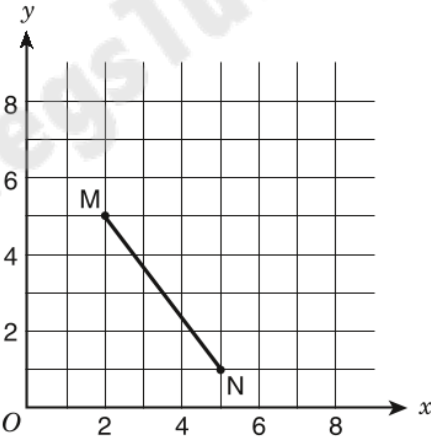
<p>1. Assume $S(x)$ equals the sum of all positive even integers less than or equal to x. What is the value of $S(7)$?</p> <p style="text-align: right;">18dup1</p>	<p>4. Simplify:</p> $\frac{p^{12} \cdot p^0}{p^{-4}}$ <p>E. 0 F. p^{-3} G. p^8 H. p^{16}</p> <p style="text-align: right;">18dup4</p>
<p>2. $\sqrt{16} \cdot \sqrt{196} =$</p> <p style="text-align: right;">18dup2</p>	<p>5.  <p style="text-align: right;">18dup5</p> <p>Water is pumped into a tank that is shaped like the right inverted cone shown above. The cone has a base diameter of 12 feet and a height of 4 feet. What is the volume, in cubic feet, of the water in the tank when the height of the water is 2 feet?</p> <p>A. 6π cu ft B. 18π cu ft C. 24π cu ft D. 48π cu ft</p> </p>
<p>3.  <p style="text-align: right;">18dup3</p> <p>If \overline{MN} is translated 1 unit to the left to produce $\overline{M'N'}$, what is the area of parallelogram $NMM'N'$?</p> <p>A. 3 square units B. 4 square units C. 5 square units D. 6 square units</p> </p>	

6.

18dup6

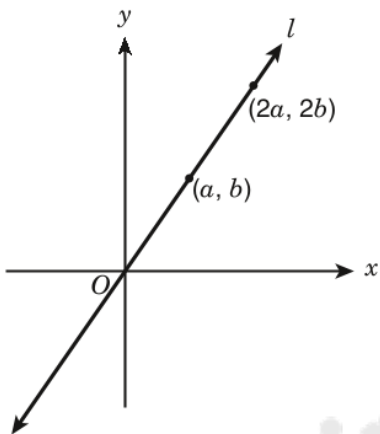

Straight line l passes through the origin, as shown in the figure above. What is the slope of line l in terms of a and b ?

- E. $\frac{a}{b}$
- F. $\frac{2b}{a}$
- G. $\frac{2a}{b}$
- H. $\frac{b}{a}$

7. The graph shows the wolf population in Yellowstone National Park since 2000. A student drew a line of best fit to model the data.

18dup7

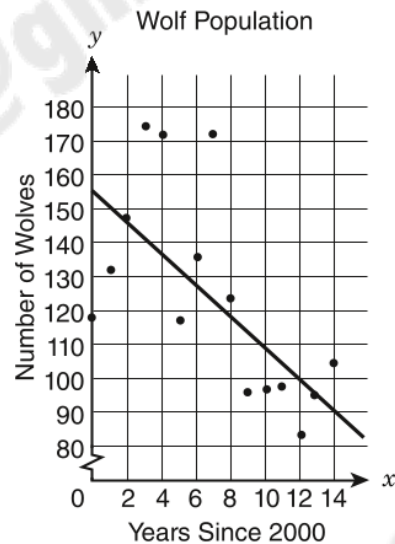

Which statement best describes the line of best fit that the student drew?

- A. The line of best fit is not a strong model for the data, because the points are not close to the line.
- B. The line of best fit is not a strong model for the data, because it does not pass through any of the data points.
- C. The line of best fit is a strong model for the data, because both the line and the data show a negative trend.
- D. The line of best fit is a strong model for the data, because about half the data points are on each side of the line.

8. To determine the price of servicing a car, a mechanic charges a fixed fee plus an hourly rate for each hour he works. If his price for 4 hours of service is \$270, and his price for 7 hours of work is \$420, what is the fixed fee that the mechanic charges?
- E. \$50
 F. \$60
 G. \$70
 H. \$120

18dup8

9.

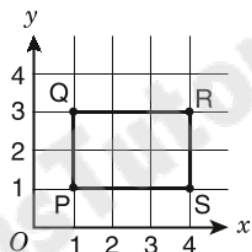

18dup9

Rectangle PQRS above is rotated 180° about the origin to form rectangle $P'Q'R'S'$. What are the coordinates of R' ?

- A. $(4, -3)$
 B. $(-4, 3)$
 C. $(-4, 1)$
 D. $(-4, -3)$

18dup10

10.

$$\frac{15.3 \times 10^{-8}}{1.5 \times 10^4}$$

What is the quotient of the expression above, expressed in scientific notation?

- E. 1.02×10^{-13}
 F. 1.02×10^{-11}
 G. 1.02×10^{-4}
 H. 1.02×10^{12}

11. Which of the following expressions is **negative** in value?

18dup11

- A. $4 - \pi$
 B. $3\pi - 9$
 C. $12 - 4\pi$
 D. $36 - 9\pi$

12.

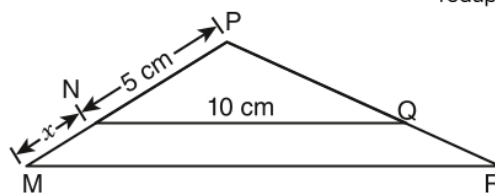

18dup12

In the figure above, $\triangle MPR$ is similar to $\triangle NPQ$. If the length of \overline{NQ} is 10 centimeters, what is the length of \overline{MR} in terms of x ?

- E. $2x$
 F. $2x + 10$
 G. $x + 5$
 H. $\frac{1}{2}x + 5$

13. The symbol $\langle x, y, z \rangle$ means $\frac{xz + xy}{2} + zy$. What is the value of $\langle 3, 4, 8 \rangle$?

- A. 15
 B. 34
 C. 50
 D. 56

Blank grids are provided on page 235.

1. A function is given on the coordinate plane.

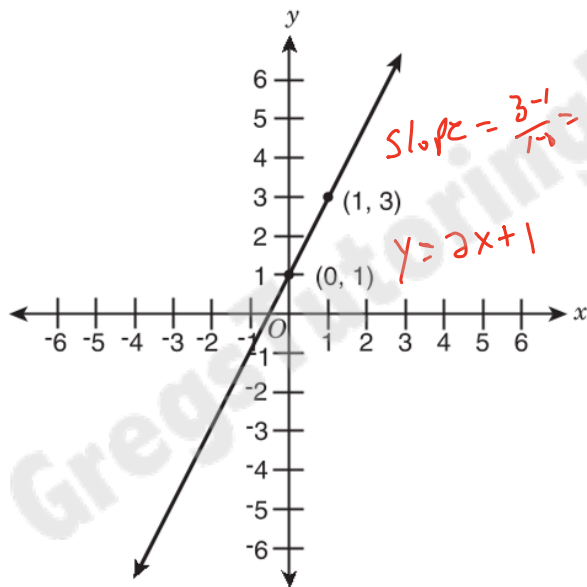

The function is linear. What is the y -value for $x = -4$?

$$y = 2(-4) + 1 = -8 + 1 = -7$$

2. $y = \frac{3}{2}x - 1$

$$x + 2y = 6$$

What is the value of x in the solution to the system of equations shown above?

$$\begin{cases} x + 2(\frac{3}{2}x - 1) = 6 \\ x + 3x - 2 = 6 \end{cases} \begin{cases} 4x = 8 \\ x = 2 \end{cases}$$

3. What is the difference in x -values in the graph from where the function first begins decreasing to where it begins decreasing again?

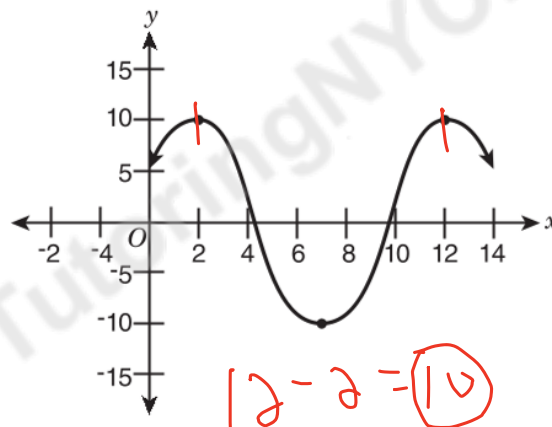

4.

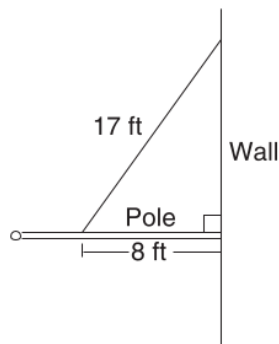

The diagram above shows a pole connected to a wall at a 90° angle. A 17-foot wire is attached to the pole at a point 8 feet out from the wall. How many feet above the pole is the wire attached to the wall?

- A. 9
- B. 13
- C. 15**
- D. 16

8-15-17

5. A researcher recorded pollution data that measured the presence of potassium and nitrates in some lakes. The scatter plot shows the data.

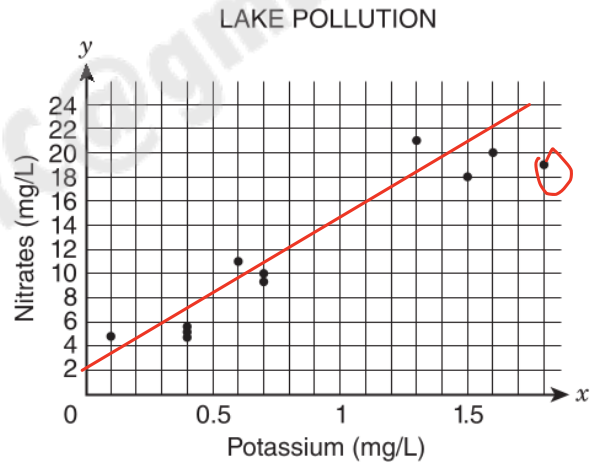

Which statement describes the data shown in the graph?

- A. The data show a nonlinear association.
- B. The data show multiple outliers.
- C. The data show a positive association.**
- D. The data show a negative association.

6. How much greater is (1.8×10^6) than (7.3×10^5) ?

- A. 1.07×10^5
- B. 1.13×10^5
- C. 1.07×10^6**
- D. 1.13×10^6

Handwritten work:
 1.8×10^6
 $- 7.3 \times 10^5$

 1.07×10^6

7. How is $0.\overline{6} \times 0.\overline{2}$ written as a fraction in simplest form?

- A. $\frac{4}{27}$ $\frac{6}{9} \times \frac{2}{9} = \frac{2}{3} \times \frac{2}{9} = \frac{4}{27}$
- B. $\frac{2}{15}$
- C. $\frac{4}{33}$
- D. $\frac{3}{25}$

8. If $2x - 6 = 8y - 10$ and $x > 5$, what is the least possible integer value of y ?

- A. 1 $2(6) - 6 = 8y - 10$
- B. 2 $12 - 6$
- C. 3 $6 + 11 = 8y$
- D. 6 $16 = 8y \quad y = 2$

9. A data set relates a car's average gas mileage, y , in miles per gallon, to its engine size, x , in liters. The equation for the line of best fit is $y = -3.25x + 34.5$. What is the meaning of the slope of the line as it relates to gas mileage and engine size?

- A. For each decrease of 1 L in engine size, the gas mileage decreases by 3.25 mpg.
- B. For each increase of 1 L in engine size, the gas mileage decreases by 3.25 mpg.
- C. For each increase of 1 mpg in gas mileage, the engine size decreases by 3.25 L.
- D. For each decrease of 3.25 mpg in gas mileage, the engine size decreases by 1 L.

10. On Saturday, the temperature changed at a constant rate from 2:00 a.m. until 2:00 p.m. At 4:00 a.m., the temperature was 47°F . At 10:00 a.m., the temperature was 32°F . What was the temperature at 2:00 a.m. on Saturday?

- A. 15°F
- B. 37°F
- C. 42°F
- D. 52°F

$\frac{6 \text{ hrs}}{-15} = \frac{2}{-5}$

$47 + 5 = 52$

- 11.

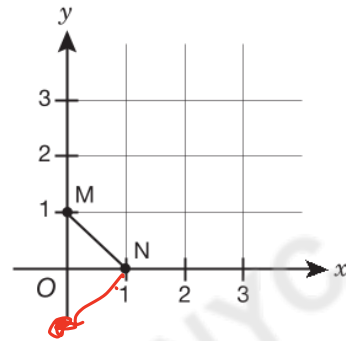

If \overline{MN} is rotated 90° clockwise about the origin, what are the coordinates of N' ?

- A. (1, 0)
- B. (0, 1)
- C. (0, -1)
- D. (-1, 0)

12.

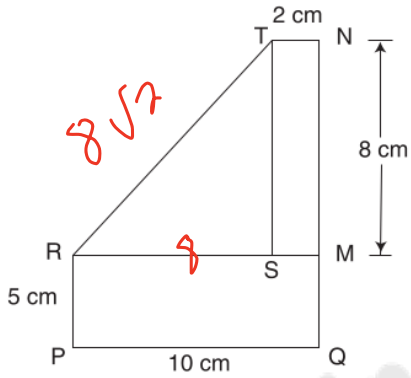

In the diagram above, $STNM$ and $PRMQ$ are rectangles, and point S is on \overline{RM} . What is the length of \overline{RT} , in centimeters?

- A. 8
- B. $\sqrt{80}$
- C. 10
- D. $\sqrt{128}$**

13.

$$N = \sqrt{y + (2x - 1)^2}$$

In the equation shown above, $y > 0$ and $N \geq 0$. What value of x will result in the **least** possible value of N ?

- A. $-\frac{1}{2}$
- B. 0
- C. $\frac{1}{4}$
- D. $\frac{1}{2}$**

$$y = 4x^2 - 4x + 1$$

$$2x - 1 = 0$$

$$2x = 1$$

$$\frac{2x}{2} = \frac{1}{2}$$

Blank grids are provided on page 273.

1. The side length of a certain square microchip, expressed in scientific notation, is 1.2×10^{-3} meter. If the area of this microchip is expressed in scientific notation as $b \times 10^a$ square meter, what is the value of a ? 1.44×10^{-6}

2. A company surveyed 800 people about their use of Soap L and Soap M. The table shows the results.

SOAP SURVEY

	Use Soap M	Do Not Use Soap M
Use Soap L	148	252
Do Not Use Soap L	264	136

Based on the results, of those who do not use Soap L, $x\%$ use Soap M. What is the value of x , expressed as a whole number?

$$\frac{264}{400} = \frac{x}{100} \quad 132 \quad (66)$$

3. The values in the table represent a function. What value of R makes the function linear?

x	y
-4	2
-1	-1
3	R

4. What is the distance, in units, between the points $(3, 20)$ and $(11, 5)$?

- E. 8
F. 15
G. 17
H. 23

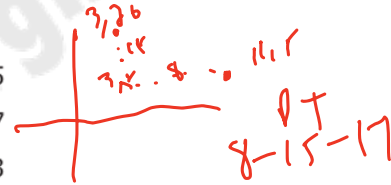

5. $3(x - 4) + 4x = 4 - x + 8(6 + x)$

$$3x - 12 + 4x = 4 - x + 48 + 8x$$

What is the solution to the equation shown above?

$$7x - 12 = 52 + 7x$$

- A. $x = 8$
B. $x = 65$
C. no solution
D. infinite number of solutions

6. Which expression represents a rational number?

- E. $\frac{3}{8}$
F. π
G. $\sqrt{3}$
H. $\sqrt{83}$

7. Which expression is equivalent to $\frac{6^{-10}}{6^2}$?

A. -6^8

B. $\frac{1}{6^{12}}$

C. 6^{-5}

D. 6^{12}

$= 6^{-10-2} = \frac{1}{6^{12}}$

8. Which table best represents a linear function?

E.

x	y
-3	5
-1	3
0	1

X 1 2 2 2

F.

x	y
-2	7
-1	4
0	3

16 16 3 X

G.

x	y
-4	-17
-3	-12
1	8

1 4 5 20 ✓ (5)

H.

x	y
-1	3
0	3
2	5

X

9. The diameter of Biological Cell A is 6×10^{-7} meter. The diameter of Biological Cell B is 3×10^{-8} meter. Which statement correctly compares the diameters of these two cells?

A. The diameter of Cell A is 2 times the diameter of Cell B.

B. The diameter of Cell B is 2 times the diameter of Cell A.

C. The diameter of Cell A is 20 times the diameter of Cell B.

D. The diameter of Cell B is 20 times the diameter of Cell A.

10⁻⁷ / 10⁻⁸ = 10

10.

SOCCER DATA

SP GP

Player	Seasons Played	Goals Scored
Isabella	3	5
Porter	6	10
Jazmine	4	6
Colin	1	3

The data in the table show the number of seasons some players on a soccer team played versus the number of goals they scored. Which conclusion is supported by the data?

E. There are multiple outliers in the data set.

F. There is a positive association between seasons played and goals scored.

G. There is a negative association between seasons played and goals scored.

H. There is no association between seasons played and goals scored.

11. What is the value of y when $0.25(y + 8) = 15$?

- A. 1.75
- B. 3.25
- C. 28
- D. 52**

$$y + 8 = 60$$

12. What is the volume, in cubic inches, of a beach ball with a diameter of 24 inches?

- ~~E. 48π~~
- ~~F. 256π~~
- ~~G. 576π~~
- H. $2,304\pi$

$$\begin{aligned} V_{SP} &= \frac{4}{3} \pi r^3 \\ &= \frac{4}{3} \pi (12^3) \\ &= 144 \times 4 \times 4 \pi \\ &= 288 \times 4 \pi \\ &= 1152 \pi \end{aligned}$$

13. How many integers, n , satisfy the condition $5 < \sqrt{n} < 6$?

- A. 0
- B. 5.5
- C. 10
- D. 11

$$\begin{aligned} 25 &< n < 36 \\ &35 \\ &\underline{-26} \\ &9 + 1 = 10 \end{aligned}$$

Blank grids are provided on page 254.

18dup1

1. Assume $S(x)$ equals the sum of all positive even integers less than or equal to x . What is the value of $S(7)$?

18dup2

2. $\sqrt{16} \cdot \sqrt{196} =$

18dup3

3.

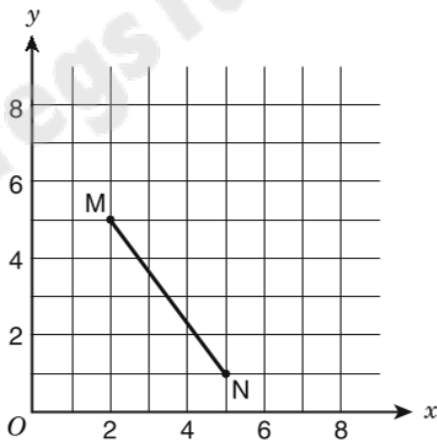

If \overline{MN} is translated 1 unit to the left to produce $M'N'$, what is the area of parallelogram $NMM'N'$?

- A. 3 square units
- B. 4 square units
- C. 5 square units
- D. 6 square units

18dup4

4. Simplify:

$$\frac{p^{12} \cdot p^0}{p^{-4}}$$

- E. 0
- F. p^{-3}
- G. p^8
- H. p^{16}

18dup5

5.

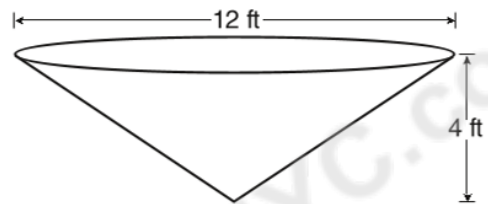

Water is pumped into a tank that is shaped like the right inverted cone shown above. The cone has a base diameter of 12 feet and a height of 4 feet. What is the volume, in cubic feet, of the water in the tank when the height of the water is 2 feet?

- A. 6π cu ft
- B. 18π cu ft
- C. 24π cu ft
- D. 48π cu ft

6.

18dup6

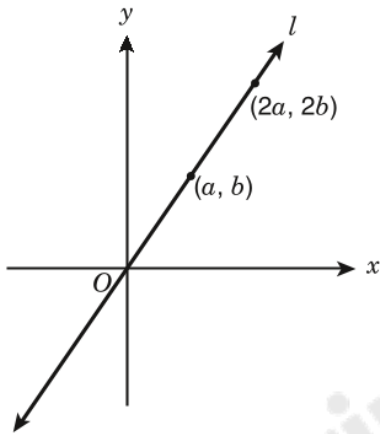

Straight line l passes through the origin, as shown in the figure above. What is the slope of line l in terms of a and b ?

- E. $\frac{a}{b}$
- F. $\frac{2b}{a}$
- G. $\frac{2a}{b}$
- H. $\frac{b}{a}$

7.

18dup7

The graph shows the wolf population in Yellowstone National Park since 2000. A student drew a line of best fit to model the data.

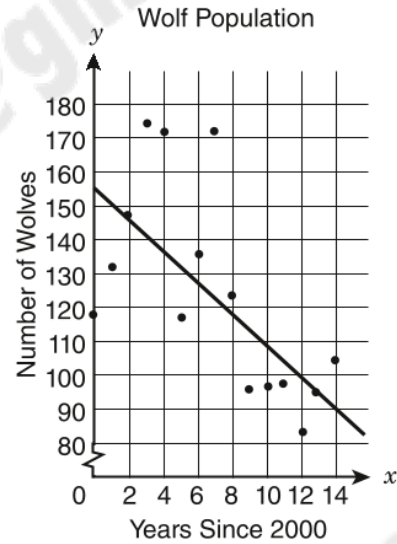

Which statement best describes the line of best fit that the student drew?

- A. The line of best fit is not a strong model for the data, because the points are not close to the line.
- B. The line of best fit is not a strong model for the data, because it does not pass through any of the data points.
- C. The line of best fit is a strong model for the data, because both the line and the data show a negative trend.
- D. The line of best fit is a strong model for the data, because about half the data points are on each side of the line.

8. To determine the price of servicing a car, a mechanic charges a fixed fee plus an hourly rate for each hour he works. If his price for 4 hours of service is \$270, and his price for 7 hours of work is \$420, what is the fixed fee that the mechanic charges?
- E. \$50
 F. \$60
 G. \$70
 H. \$120

18dup8

9.

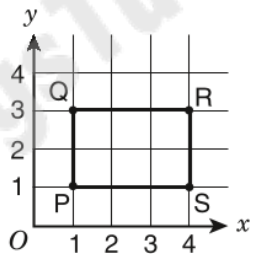

18dup9

Rectangle PQRS above is rotated 180° about the origin to form rectangle $P'Q'R'S'$. What are the coordinates of R' ?

- A. $(4, -3)$
 B. $(-4, 3)$
 C. $(-4, 1)$
 D. $(-4, -3)$

10.

$$\frac{15.3 \times 10^{-8}}{1.5 \times 10^4}$$

18dup10

What is the quotient of the expression above, expressed in scientific notation?

- E. 1.02×10^{-13}
 F. 1.02×10^{-11}
 G. 1.02×10^{-4}
 H. 1.02×10^{12}

18dup11

11. Which of the following expressions is **negative** in value?

- A. $4 - \pi$
 B. $3\pi - 9$
 C. $12 - 4\pi$
 D. $36 - 9\pi$

12.

18dup12

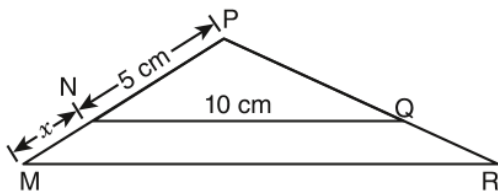

In the figure above, $\triangle MPR$ is similar to $\triangle NPQ$. If the length of \overline{NQ} is 10 centimeters, what is the length of \overline{MR} in terms of x ?

- E. $2x$
- F. $2x + 10$
- G. $x + 5$
- H. $\frac{1}{2}x + 5$

13. The symbol $\langle x, y, z \rangle$ means $\frac{xz + xy}{2} + zy$. What is the value of $\langle 3, 4, 8 \rangle$?

18dup13

- A. 15
- B. 34
- C. 50
- D. 56

Blank grids are provided on page 292.

1. $0.44 = \frac{x}{25}$

What is the value of x in the equation?

2. The two equations $y = 6x - 5$ and $y = -3x + 7$ are represented as lines on a graph. What is the y -value of the point of intersection of the two lines?

3. The function $y = 2x - 4$ is graphed. The line of the graph travels through point $(0, -4)$ and point $(12, y)$. What is the value of y in point $(12, y)$?

4. Which number has a value that is located between 7 and 8 on a number line?

E. $\sqrt{37}$

F. $\sqrt{47}$

G. $\sqrt{57}$

H. $\sqrt{67}$

5.

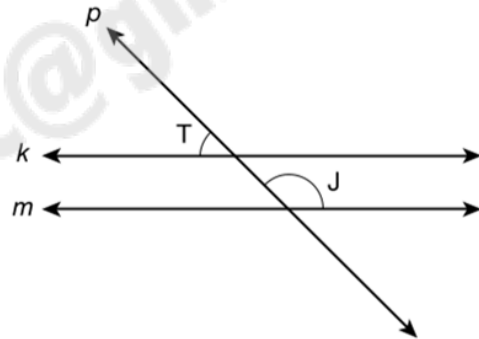

In the figure above, $k \parallel m$. Straight line p intersects both line k and line m . The measure of $\angle T$ is 47° . What is the measure of $\angle J$?

A. 43°

B. 47°

C. 133°

D. 137°

6. Which of these numbers is irrational?

E. $0.\bar{7}$

F. $\sqrt{9}$

G. $\frac{9}{7}$

H. $\sqrt{7}$

7. Triangles JKL and J''K''L'' are congruent triangles.

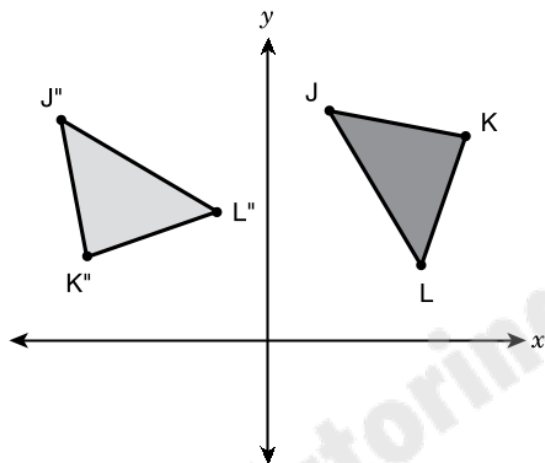

Which two transformations were used to transform JKL to J''K''L''?

- A. A translation to the right, and then a reflection across the y -axis
- B. A reflection across the x -axis, and then a clockwise rotation of 270°
- C. A rotation of 180° about the origin, and then a translation across the x -axis
- D. A reflection across the y -axis, and then a counterclockwise rotation of 90° about its center

8. The scatter plot shows a set of data.

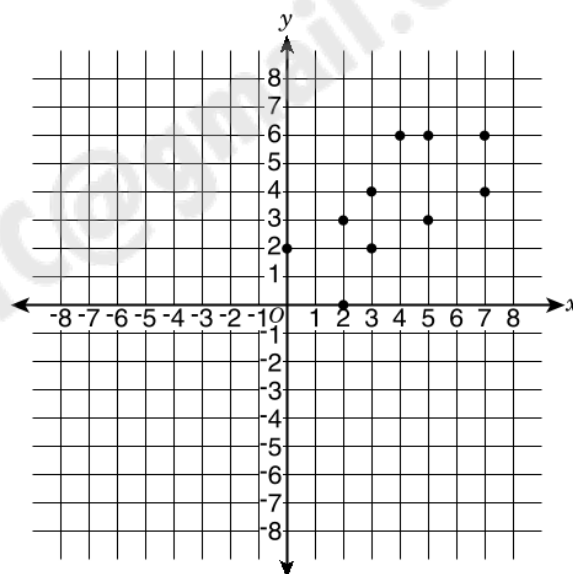

Which equation represents the most accurate line of best fit for the data shown in the scatter plot?

- E. $y = (-x)$
- F. $y = x$
- G. $y = (-x) + 2$
- H. $y = x + 2$

9. What is the point of intersection of the graphs of $y = -4x + 3$ and $y = 2x + 5$?

- A. $(-\frac{1}{3}, 4\frac{1}{3})$
B. $(-\frac{1}{3}, 5\frac{2}{3})$
C. $(\frac{1}{3}, 1\frac{2}{3})$
D. $(\frac{1}{3}, 5\frac{2}{3})$

10. The table below represents a linear function.

x	y
12	30
24	40
36	50

A second linear function is represented by the equation $y = 4x + 3$. Which statement comparing the rates of change of the two functions is true?

- E. The rate of change for $y = 4x + 3$ is less because $3 < 20$.
F. The rate of change for $y = 4x + 3$ is less because $-\frac{3}{4} > -24$.
G. The rate of change for $y = 4x + 3$ is greater because $4 > \frac{5}{6}$.
H. The rate of change for $y = 4x + 3$ is greater because $-\frac{3}{4} < \frac{5}{6}$.

11. How many solutions are there to the equation $|4x + 6| = -2$?

- A. No solutions
B. One solution
C. Two solutions
D. An infinite number of solutions

12. The scatter plot shows data that a researcher collected.

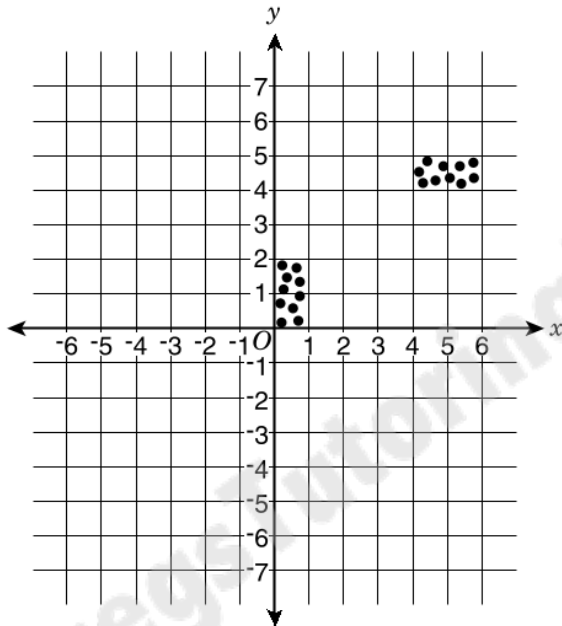

Which statement correctly describes the data?

- E. The data have a positive linear association.
- F. The data have a negative linear association.
- G. The data have clustering.
- H. The data have outliers.

- 13.

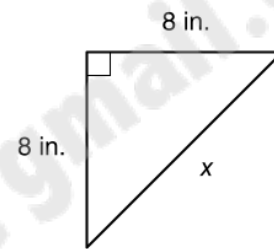

What is the length of x in the triangle?

- A. $\sqrt{89}$ in.
- B. $\sqrt{98}$ in.
- C. $\sqrt{128}$ in.
- D. $\sqrt{162}$ in.

Mathematics Sample Questions

1. A function is given on the coordinate plane. 20dup1

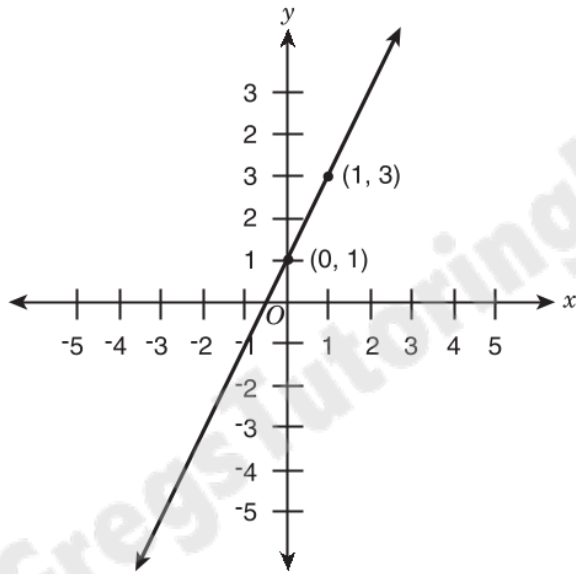

The function is linear. What is the y-value for $x = -4$?

2. What is the difference in x-values in the graph from where the function first begins decreasing to where it begins decreasing again? 20dup3

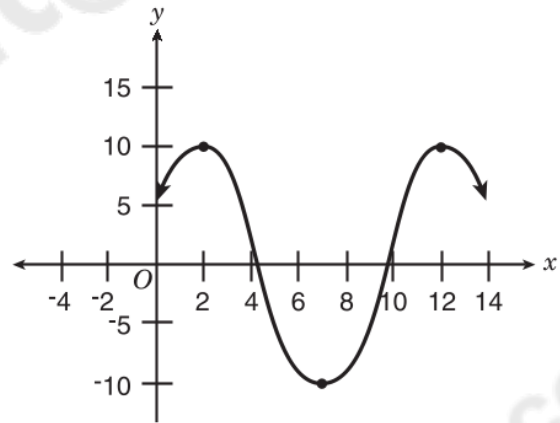

3. 20dup2

$$\begin{cases} y = \frac{3}{2}x - 1 \\ x + 2y = 6 \end{cases}$$

What is the value of x in the solution to the system of equations shown above?

20dup4

4.

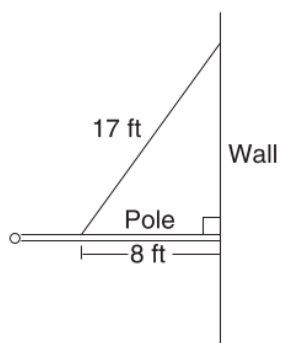

The diagram above shows a pole connected to a wall at a 90° angle. A 17-foot wire is attached to the pole at a point 8 feet out from the wall. How many feet above the pole is the wire attached to the wall?

- E. 9
- F. 13
- G. 15
- H. 16

20dup5

5. A researcher recorded pollution data that measured the presence of potassium and nitrates in some lakes. The scatter plot shows the data.

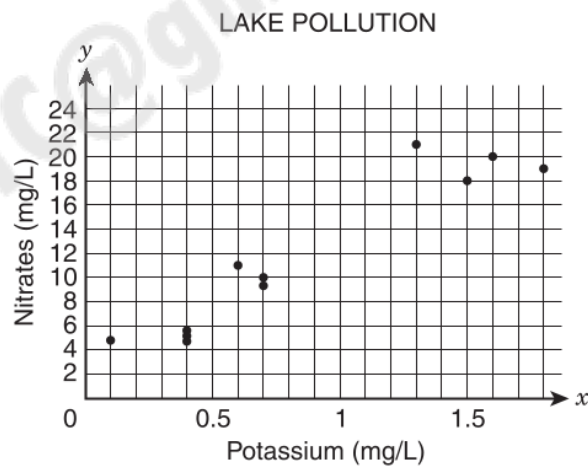

Which statement describes the data shown in the graph?

- A. The data show a nonlinear association.
- B. The data show multiple outliers.
- C. The data show a positive association.
- D. The data show a negative association.

20dup6

6. How much greater is (1.8×10^6) than (7.3×10^5) ?
- E. 1.07×10^5
 - F. 1.13×10^5
 - G. 1.07×10^6
 - H. 1.13×10^6

20dup7

7. How is $0.\overline{6} \times 0.\overline{2}$ written as a fraction in simplest form?

A. $\frac{4}{27}$

B. $\frac{2}{15}$

C. $\frac{4}{33}$

D. $\frac{3}{25}$

20dup8

8. If $2x - 6 = 8y - 10$ and $x > 5$, what is the **least** possible integer value of y ?

E. 1

F. 2

G. 3

H. 6

20dup9

9. A data set relates a car's average gas mileage, y , in miles per gallon, to its engine size, x , in liters. The equation for the line of best fit is $y = -3.25x + 34.5$. What is the meaning of the slope of the line as it relates to gas mileage and engine size?

A. For each decrease of 1 L in engine size, the gas mileage decreases by 3.25 mpg.

B. For each increase of 1 L in engine size, the gas mileage decreases by 3.25 mpg.

C. For each increase of 1 mpg in gas mileage, the engine size decreases by 3.25 L.

D. For each decrease of 3.25 mpg in gas mileage, the engine size decreases by 1 L.

- 10.** On Saturday, the temperature changed at a constant rate from 2:00 a.m. until 2:00 p.m. At 4:00 a.m., the temperature was 47° F. At 10:00 a.m., the temperature was 32° F. What was the temperature at 2:00 a.m. on Saturday?

- E.** 15° F
- F.** 37° F
- G.** 42° F
- H.** 52° F

- 11.**

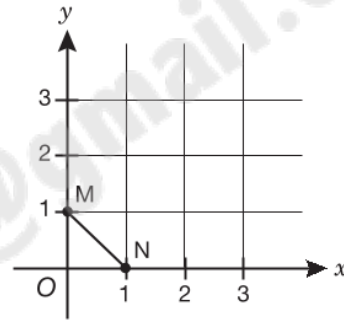

If \overline{MN} is rotated 90° clockwise about the origin, what are the coordinates of N' ?

- A.** (1, 0)
- B.** (0, 1)
- C.** (0, -1)
- D.** (-1, 0)

12.

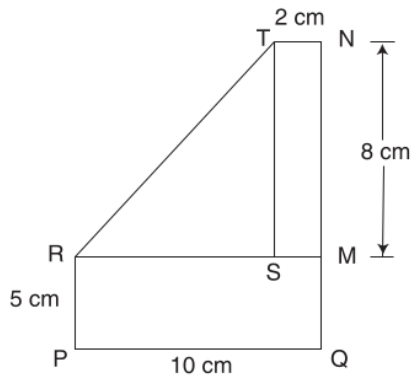

In the diagram above, $STNM$ and $PRMQ$ are rectangles, and point S is on \overline{RN} . What is the length of \overline{RT} , in centimeters?

- E. 8
- F. $\sqrt{80}$
- G. 10
- H. $\sqrt{128}$

13.

$$N = \sqrt{y + (2x - 1)^2}$$

In the equation shown above, $y > 0$ and $N \geq 0$. What value of x will result in the **least** possible value of N ?

- A. $-\frac{1}{2}$
- B. 0
- C. $\frac{1}{4}$
- D. $\frac{1}{2}$